

To be determined base on the exact location of construction site.

Assembly type	Standard	Description
wall assemblies	R-_____	_____
fenestration/openings	U-_____	_____
roof/ceiling assemblies	R-_____	_____
floors over conditioned spaces	R-_____	_____
slab on grade	R-_____	_____
crawl spaces	R-_____	_____
lower level walls: continuous insulation	R-_____	_____
lower level walls: cavity insulation	R-_____	_____

PROJECT DATA

Project Name: Prototype Two-Unit Residence

Project Address: _____

Building Owner: _____

Governing Codes

2015 Michigan Building Code
2018 Michigan Plumbing Code
2015 Michigan Mechanical Code
2017 Michigan Electrical Rules

Project Type: New construction

Section R302.3 Two family dwellings.

Dwelling units in two-family dwelling shall be separated from each other by wall and floor assemblies having not less than 1-hour fire resistance test in accordance with ASTM E119 or UL 263. Fire-resistance-rated floor/ceiling and wall assemblies shall extend to and be tight against the exterior wall, and wall assemblies shall extend from the foundation to the underside of the roof sheathing. Exceptions: Wall assemblies need not extend through attic spaces where ceiling is protected by not less than 5/8 inch (15.9 mm) Type X gypsum board, and attic draft stop constructed as specified in Section R302.12 is provided above and along the wall assembly separating the dwelling and the structural framing supporting the ceiling is protected by not less than 1/2 inch (12.7) gypsum board or equivalent.

Section 302.4.2

Any penetrations in the Floor/Ceiling between units will have to Fire Rated per section 302.4.2

Building Height

Two stories

Building Area

Lower Level: 978 ft² (for full basement)
Main Level: 999 ft²
Upper Level: 999 ft²
1,998 ft² (does not include Lower Level)

Required fire resistance ratings [R302.1(1)]

Walls: 0 hour
Projections: 0 hour
Openings in a wall: 0 hour
Non-bearing walls: 0 hour
Penetrations: 0 hour

Section R307 - Toilet, Bath And Shower Spaces

R307.1 Space required. Fixtures shall be space in accordance with Figure R3037.1, and in accordance with requirements of Section P705.12.

Section R311.6 - Hallways

The width of a hallway shall be not less than 3 feet.

Section R311.7 Stairways.

R311.7.1 Width. Stairways shall be not less than 36 inches (914mm) in clear width at all points above the permitted handrail height and below the required headroom height. Handrails shall not project more than 4 1/2 inches on either side of the stairway and the clear width of the stairway at and below the handrail height, including tread and landings, shall not be less than 31 1/2 inches where a handrail is installed on one side and 27 inches where handrails are provided on both sides.

R311.7.4.1 Riser Height.

The maximum riser height shall be 8 1/4 inches.

R311.7.4.2 Tread Depth.

The minimum tread depth shall be 9 inches.

R311.7.8 Handrails.

Handrails shall be provided on not less than one side of each continuous run of treads or flight with four or more risers.

R3.11.7.8.1 Height.

Not less than 34 inches and not more than 38 inches.

R311.7.8.2 Continuity.

Handrails for stairways shall be continuous for the full length of the flight, from a point directly above the lowest riser of the flight.

Section R314 Smoke Alarms

R314.2.1 New Construction.

Smoke alarms shall be provided in dwellings.

R314.3 Location.

- In each sleeping room.
- Outside each separate sleeping area in the immediate vicinity of the bedrooms.

R314.4 Interconnection.

Where more than 1 smoke alarm is required to be installed within an individual dwelling unit in accordance with Section R34.3, the alarm shall be interconnected.

R315 Carbon Monoxide Alarms.

R315.2.1 New Construction.
For new construction, carbon monoxide alarms shall be provided in dwelling units where either or both of the following exist:

- The dwelling unit contains a fuel-fired appliance.

DRAWING SCHEDULE

- A1.0 Cover Sheet and Building Info
- A2.0 Foundation Plan
- A2.1 Main Floor Plan
- A2.2 Upper Floor Plan
- A2.3 Roof Plan & Attic Plan
- A3.0 Building Section & Wall Section
- A4.0 Building Elevations
- A4.1 Building Elevations
- A5.0 Interior Elevations
- A6.0 Wall Details

- X1.0 Options

- S1.0 Structural Plans

- E2.0 Main Electrical Plan
- E2.1 Upper Electrical Plan

- M2.0 Main Mechanical Plan
- M2.1 Upper Mechanical Plan

- P2.0 Plumbing Plans

Disclaimer: The drawings found within this set are Substantially Complete, and are marked "Not for Construction," as it will be necessary for each site-specific development to employ architects and/or engineers to evaluate local conditions, make necessary adjustments required for local permitting. Individuals using these drawings shall seek any necessary professional services before starting the building process.

SYMBOL LEGEND

- Section Number
- Building Section
- Sheet Number
- Detail Number
- Detail flag
- Sheet Number
- Detail Numbers
- Interior Elevation
- Sheet Number
- Vertical Elevation
- Window Call Out
- Door Call Out
- Note Call Out

Owner

Architect

Engineer

Developer/Contractor

ABBREVIATIONS

AB	Anchor Bolt	GALV	Galvanized	R	R-Value
AC	Air Conditioning	GLB	Glue Laminated Beam	REF	Refrigerator
A/C	Asphaltic Concrete	GYP	Gypsum	REINF	Reinforced (ing)
ARCH	Architectural	HVAC	Heating & Cooling Equip	SC	Solid core
BLKG	Blocking	HRV	Heat Recovery Ventil.	SQFT	Square feet
CMU	Concrete Masonry Unit	HB	Hose Bib	SHTG	Sheathing
CONC	Concrete	HC	Hollow Core	SIM	Similar
CONT	Continuous	HDR	Header	SS	Stainless steel
DBL	Double	HORIZ	Horizontal	TBD	To be determined
DET	Detail	INSUL	Insulation	TO	Top of
DF	Douglas Fir	INT	Interior	TYP	Typical
DS	Downspout	MAX	Maximum	VERT	Vertical
DW	Dishwasher	MC	Medicine cabinet	U	U-Value
EA	Each	MFR	Manufacturer	W/	With
EQUIP	Equipment	MIN	Minimum	W/O	Without
(E)	Equal	NTS	Not to Scale		
FF	Finish Floor	OC	On center		
FTG	Footing	PLYWD	Plywood		
GA	Gauge	RO	Rough opening		

BUILDING DATA

DESIGN CRITERIA

To be determined base on the exact location of construction site.

Roof Dead: ____ psf Wind: _____
Roof Live: ____ psf Septic: _____

Soil Bearing: ____psf

WALL TYPES - refer to Sheet A6.0 for details

- Wall Type 1: Exterior Walls
- Wall Type 2: Interior Partition walls
- Wall Type 3: Interior Rated Walls
- Wall Type 4: Foundation Walls I
- Wall Type 5: Foundation Walls II

Disclaimer: The drawings found within this set are Substantially Complete, but are marked "Not for Construction," as it will be necessary for each site-specific development to employ architects and/or engineers to evaluate local conditions, make necessary adjustments required for local permitting. Some items are indicated as blanks for local verification.

Do not scale.
Use figured
dimensions only.

MML Review Set
22 AUG 2022

NOT FOR CONSTRUCTION

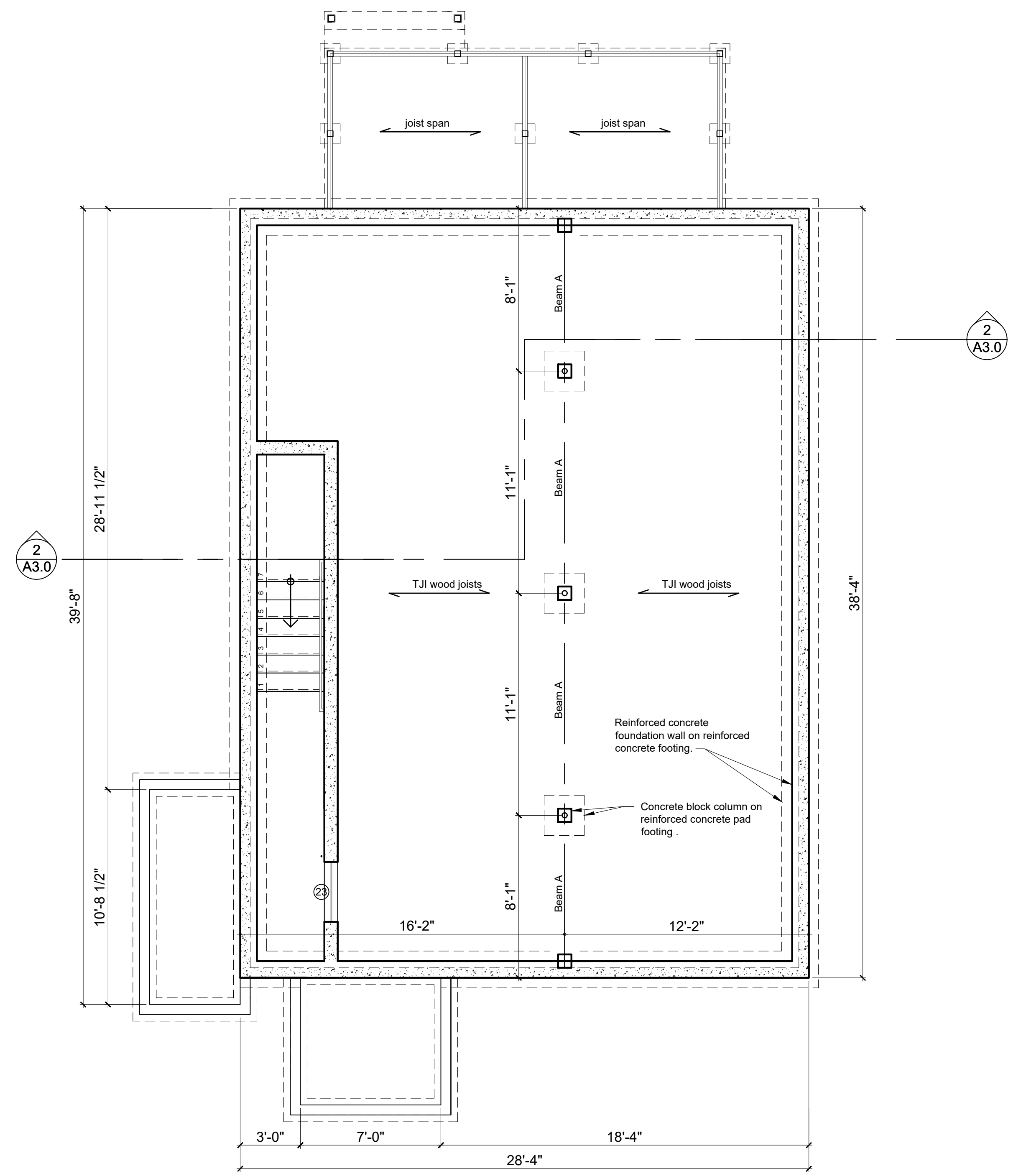

1 Foundation Plan
1/4" = 1'-0"

THE LINDEN
Michigan Municipal League

Job Number:
2022xx
Title:
FOUNDATION
PLAN

A2.0

Mark	Description	Manufacturer	Collection	Color
PT1	Paint 1			
PT2	Paint 2			
PT3	Paint 3			
TILE1	Ceramic 1			
TILE2	Ceramic 2			
LVT 1	Luxury Vinyl Tile			
CPT1	Carpet 1			
CPT2	Carpet 2			
TB1	Tile Base			
VB	Vinyl Base			

Hardware Descriptions
Schlage or approved equal

ENTRY
The deadbolt is engaged or retracted by an outside key or an inside thumb-turn. When the deadbolt is engaged the outside grip is locked and will not retract the latchbolt. When the deadbolt is engaged the inside grip simultaneously retracts both the deadbolt and the latchbolt. The latchbolt alone can be locked by a toggle (engaging the deadbolt is not required to lock the outside grip).

PASSAGE
Latchbolt is retracted by the grip on either side. Both grips are always free

PRIVACY
The latchbolt is retracted by the inside grip or an outside key. The latchbolt is retracted by the outside grip unless the grip is locked by a thumbturn from the inside. The latchbolt / outside grip cannot be locked by a key from the outside.

CLOSET
Ball catch is disengaged when handle is pulled. No interior handle

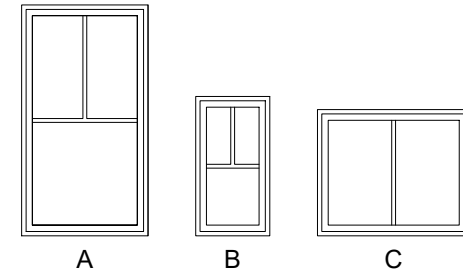

Window Types

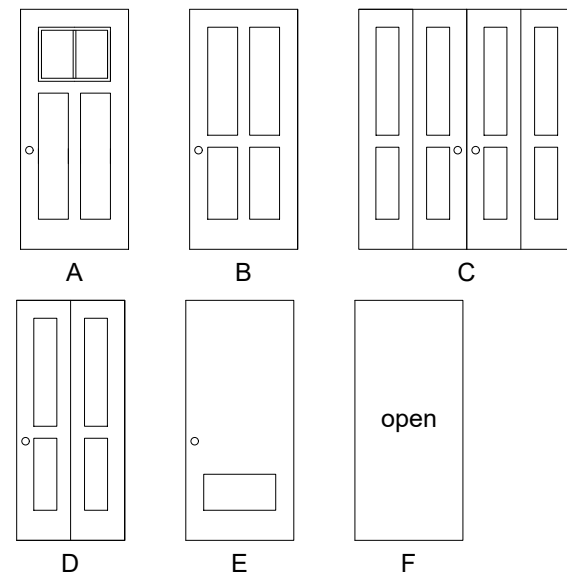

Door Types

MAIN LEVEL FINISH SCHEDULE

NO.	ROOM	FLOOR	BASE	WALLS	CEILING	NOTES
100	LIVING	LVT	TB1			Wood Look Luxury Vinyl Tile
101	KITCHEN	TILE1	TB1			
102	BATH	TILE2	TB1			
103	BEDROOM 2	CPT1	VB			
104	BEDROOM 1	CPT1	VB			
105	HALL	LVT1	VB			Wood Look Luxury Vinyl Tile
106	STAIR HALL	LVT	VB			Wood Look Luxury Vinyl Tile

MAIN LEVEL WINDOW SCHEDULE

MARK	QTY	WIDTH	HEIGHT	DESCRIPTION	NOTES
A	7	2'-5"	4'-5"	CASEMENT	
B	0	1'-5"	2'-8"	CASEMENT	
C	3	2'-11"	2'-8"	CASEMENT	

DOOR SCHEDULE

MARK	ID	SIZE	SWING	MATERIAL	FRAME	HARDWARE	NOTES
1	A	36" x 80"	LEFT	STEEL	PAINTED	ENTRY	
2	B	32" x 80"	LEFT	WOOD	PAINTED	CLOSET	
3	B	36" x 80"	LEFT	WOOD	PAINTED	PRIVACY	
4	D	36" x 80"	BIFOLD	WOOD	PAINTED	PRIVACY	
5	B	36" x 80"	RIGHT	WOOD	PAINTED	PRIVACY	
6	A	36" x 80"	RIGHT	STEEL	PAINTED	ENTRY	
7	B	36" x 80"	LEFT	WOOD	PAINTED	PRIVACY	
8	C	72" x 80"	BIFOLD	WOOD	PAINTED	CLOSET	
9	B	36" x 80"	LEFT	WOOD	PAINTED	CLOSET	
10	B	36" x 80"	RIGHT	WOOD	PAINTED	CLOSET	
11	A	36" x 80"	RIGHT	STEEL	PAINTED	ENTRY	
12	B	36" x 80"	LEFT	STEEL	PAINTED	ENTRY	
13	D	36" x 80"	BIFOLD	WOOD	PAINTED	CLOSET	
14	B	36" x 80"	RIGHT	WOOD	PAINTED	CLOSET	
15	B	36" x 80"	RIGHT	WOOD	PAINTED	CLOSET	
16	B	32" x 80"	LEFT	WOOD	PAINTED	CLOSET	
17	B	36" x 80"	LEFT	WOOD	PAINTED	PRIVACY	
18	D	36" x 80"	BIFOLD	WOOD	PAINTED	CLOSET	
19	B	36" x 80"	RIGHT	WOOD	PAINTED	PRIVACY	
20	A	36" x 80"	RIGHT	STEEL	PAINTED	ENTRY	
21	B	36" x 80"	LEFT	WOOD	PAINTED	PRIVACY	
22	B	72" x 80"	DOUBLE	WOOD	PAINTED	CLOSET	
23	-	36" x 80"	-	NONE	NONE	NONE	Access Panel to Crawl Space

2 Schedules
No scale

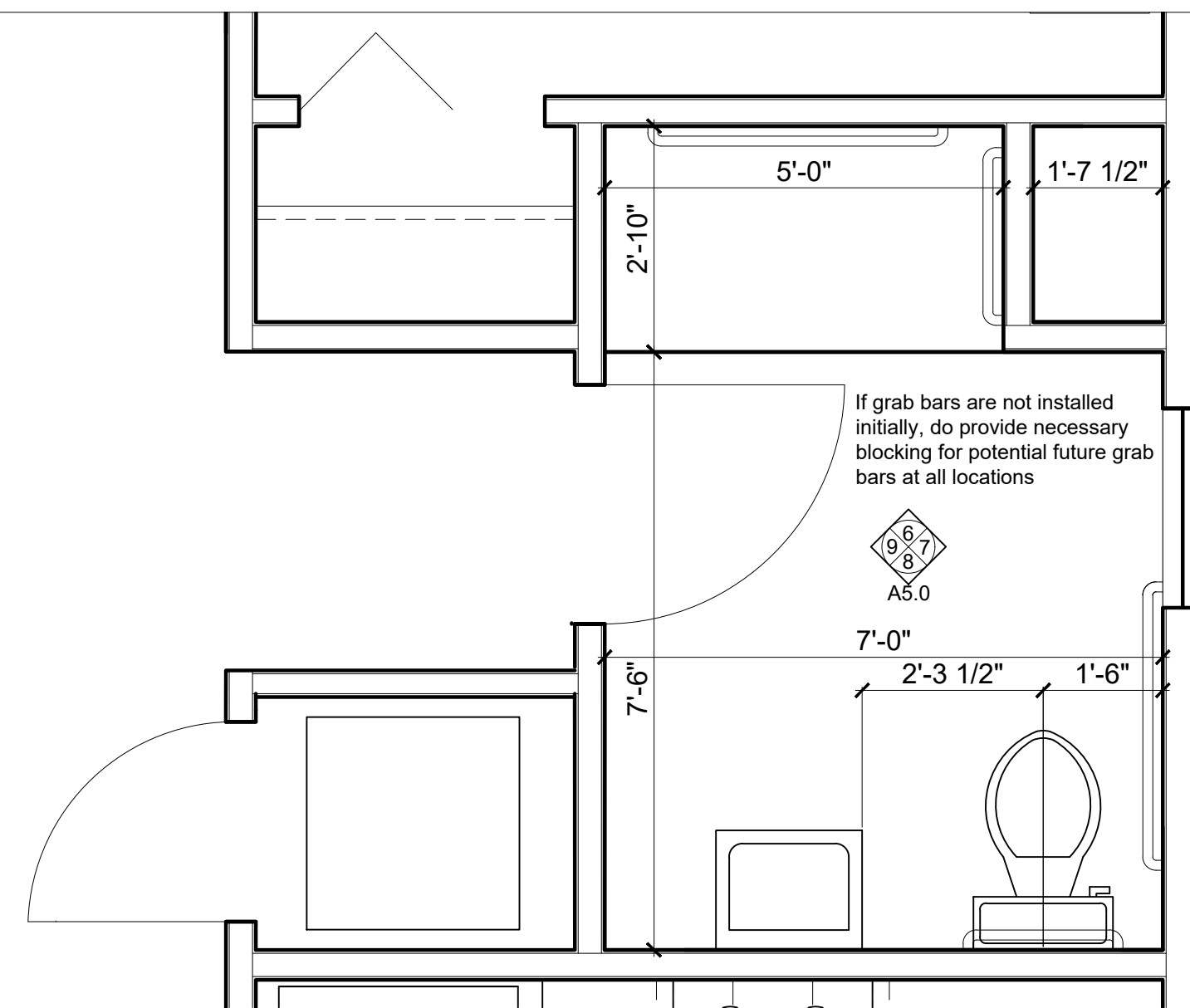

4 Main Level Bathroom Layout
1/2" = 1'-0"

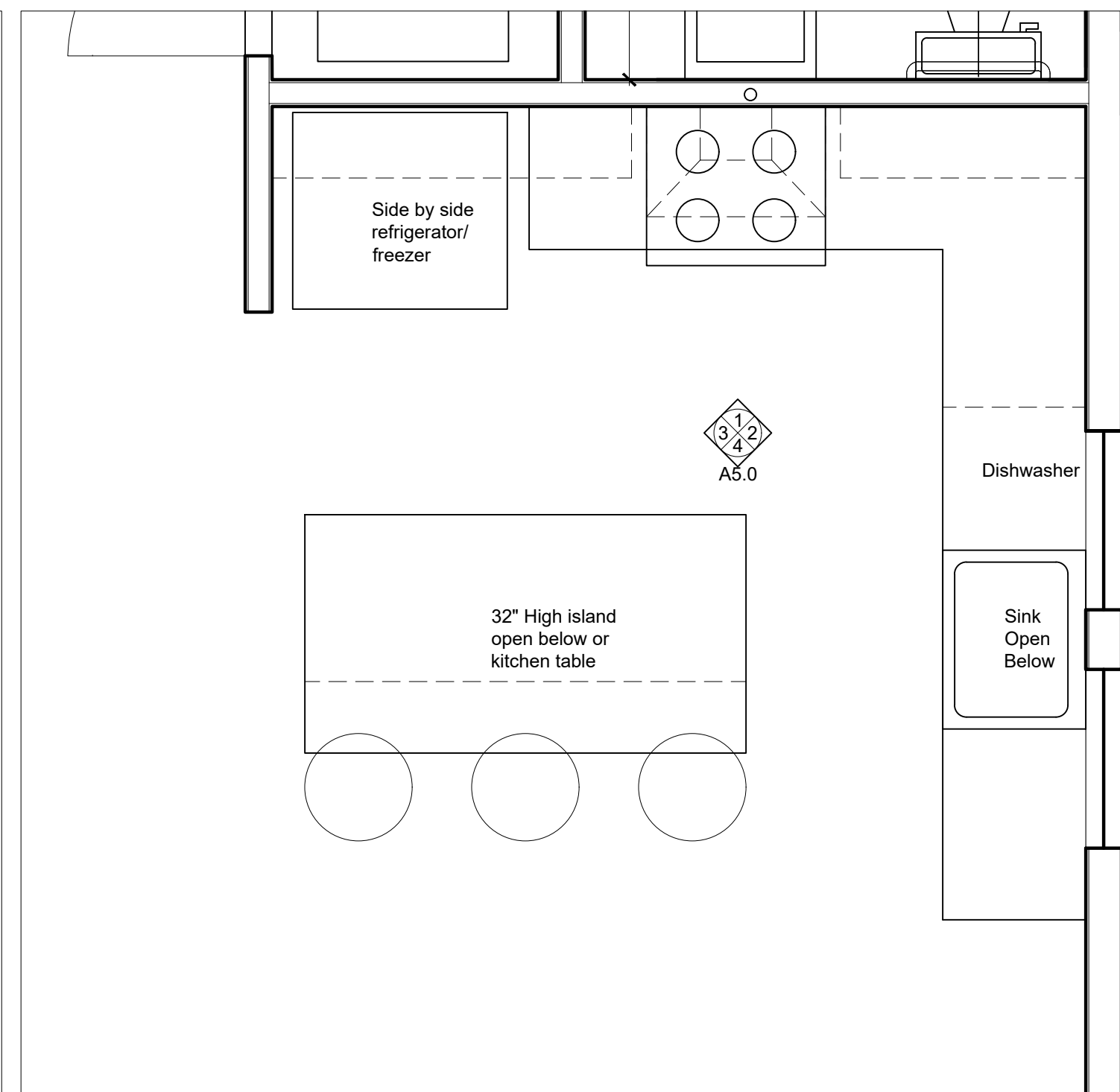

3 Main Level Kitchen Layout
1/2" = 1'-0"

WALL TYPES - refer to Sheet A6.0 for details

- Wall Type 1: Exterior Walls
- Wall Type 2: Interior Partition walls
- Wall Type 3: Interior Rated Walls
- Wall Type 4: Foundation Walls I
- Wall Type 5: Foundation Walls II

Disclaimer: The drawings found within this set are Substantially Complete, but are marked "Not for Construction," as it will be necessary for each site-specific development to employ architects and/or engineers to evaluate local conditions, make necessary adjustments required for local permitting. Some items are indicated as blanks for local verification.

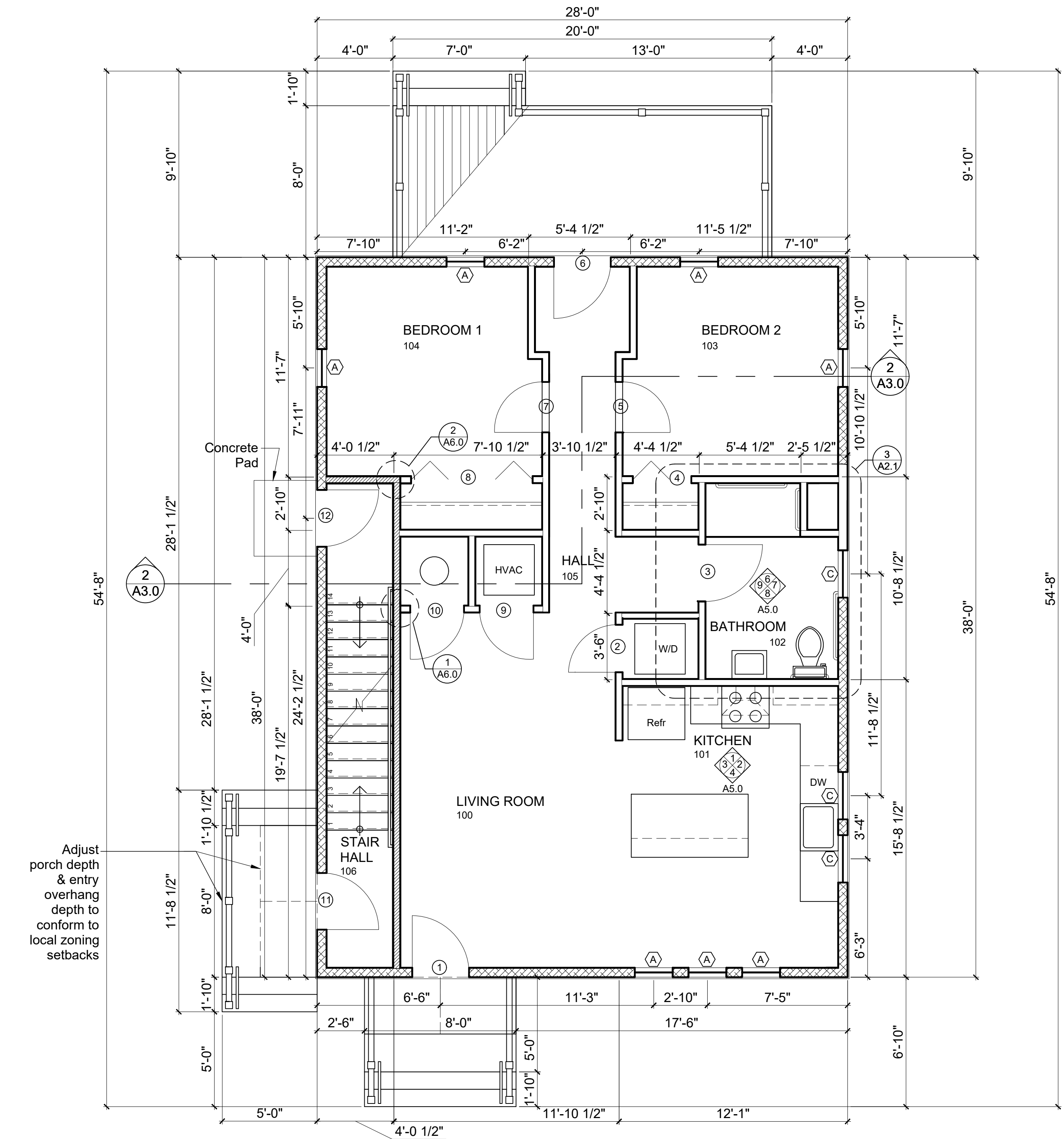

1 Main Floor Plan
1/4" = 1'-0"

Do not scale.
Use figured dimensions only.

MML Review Set
22 AUG 2022

NOT FOR CONSTRUCTION

THE LINDEN
Michigan Municipal League

Job Number:
2022xx
Title:
MAIN FLOOR PLAN

A2.1

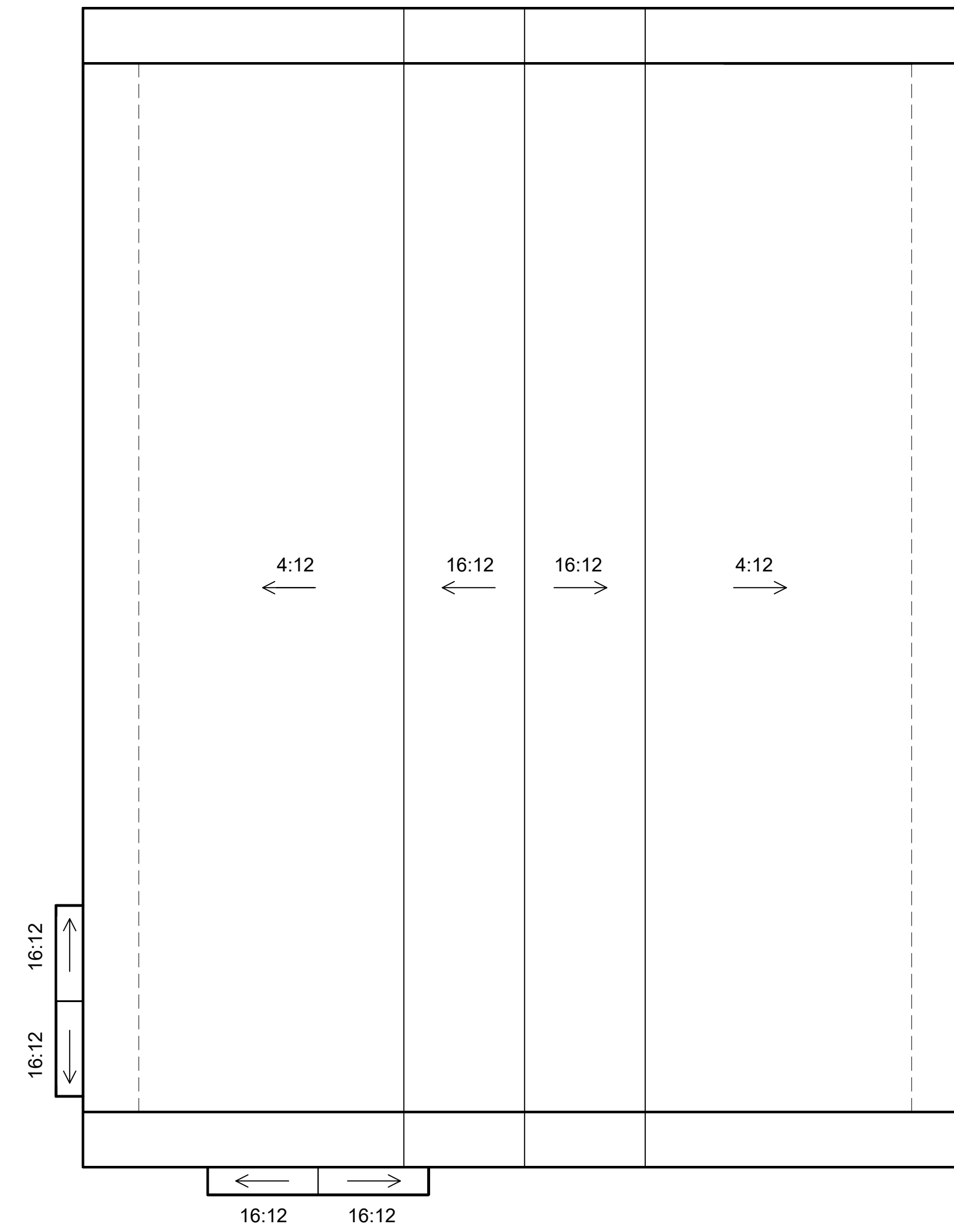

② Roof Plan
1/4" = 1'-0"

WALL TYPES - refer to Sheet A6.0 for details

- Wall Type 1: Exterior Walls
- Wall Type 2: Interior Partition walls
- Wall Type 3: Interior Rated Walls
- Wall Type 4: Foundation Walls

Disclaimer: The drawings found within this set are Substantially Complete, but are marked "Not for Construction, as it will be necessary for each site-specific development to employ architects and/or engineers to evaluate local conditions, make necessary adjustments required for local permitting. Some items are indicated as blanks for local verification.

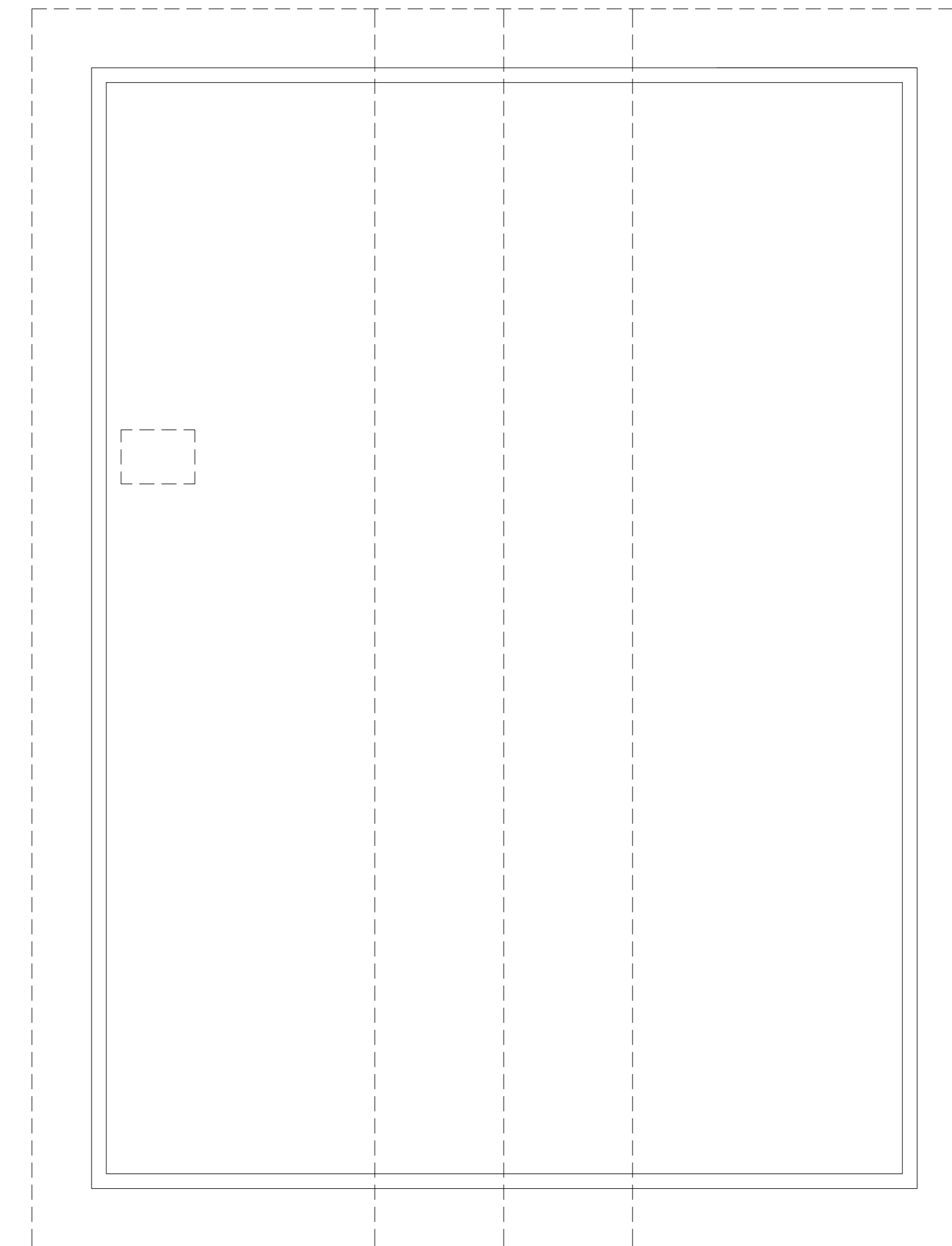

① Attic Plan
1/4" = 1'-0"

Do not scale.
Use figured
dimensions only.

MML Review Set
22 AUG 2022

NOT FOR CONSTRUCTION

THE LINDEN
Michigan Municipal League

Job Number:
2022xx
Title:
ATTIC & ROOF
PLANS

A2.3

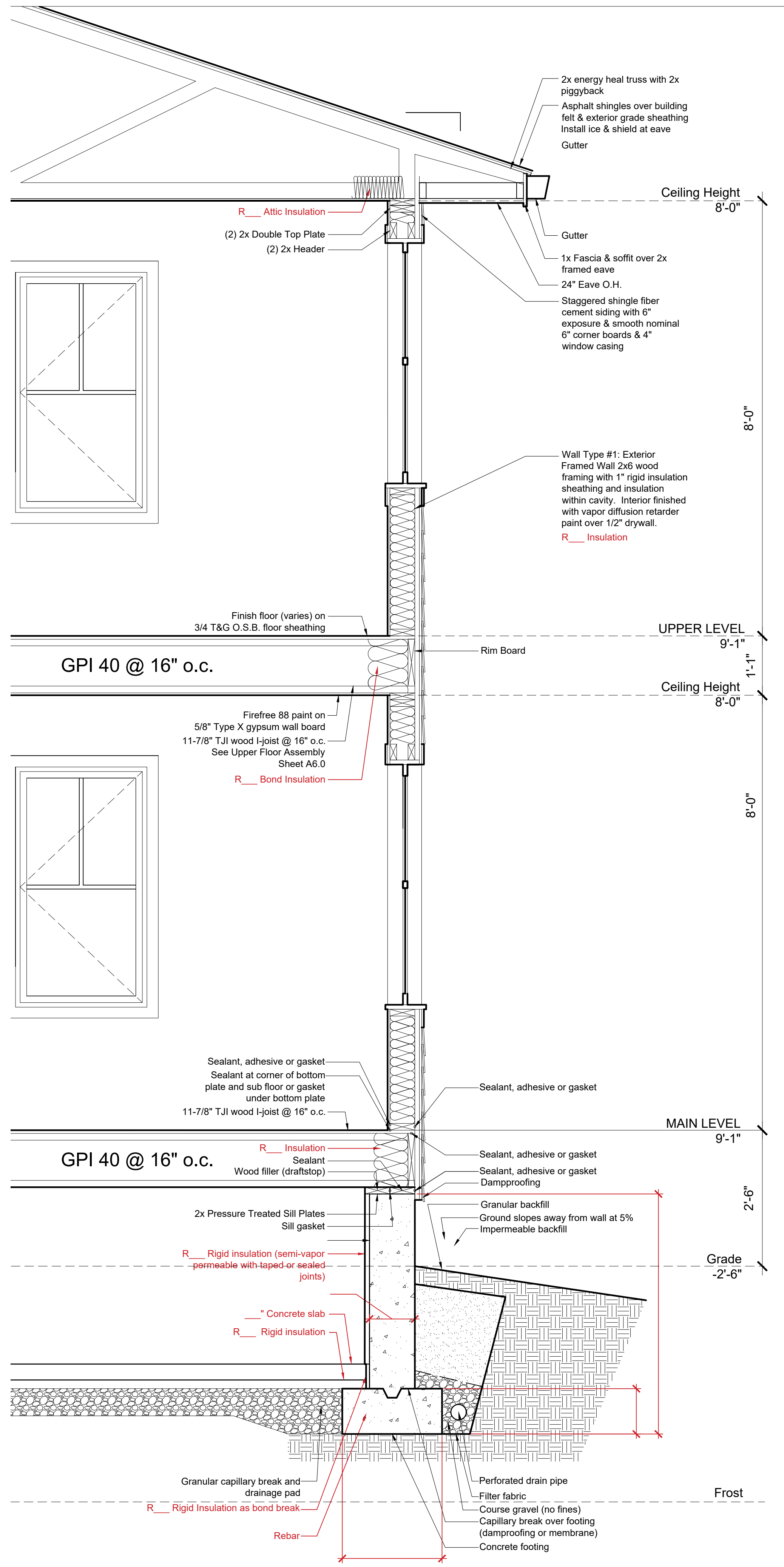

2 Wall Section
3/4" = 1'-0"

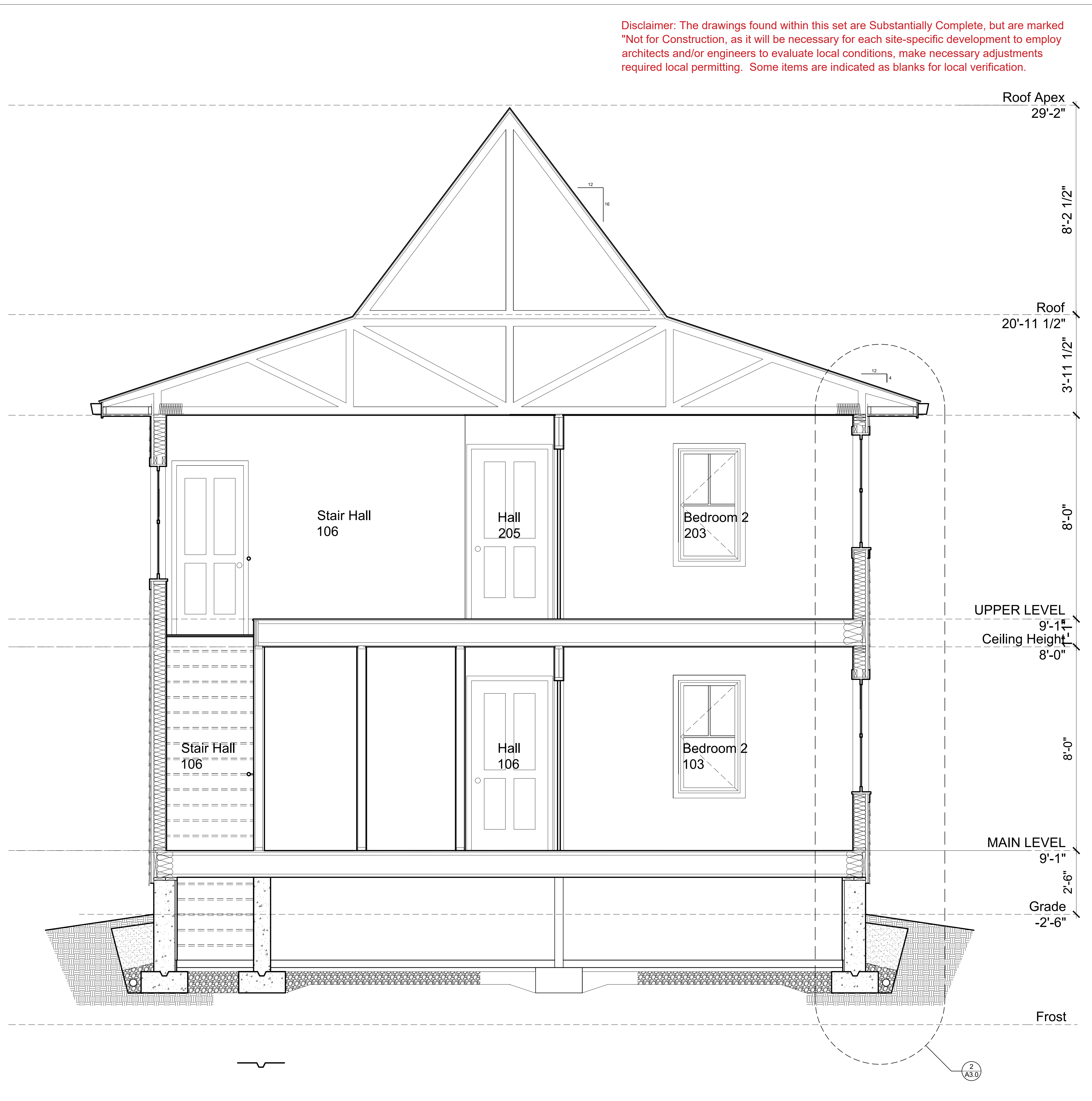

1 Building Section
1/2" = 1'-0"

Disclaimer: The drawings found within this set are Substantially Complete, but are marked "Not for Construction, as it will be necessary for each site-specific development to employ architects and/or engineers to evaluate local conditions, make necessary adjustments required local permitting. Some items are indicated as blanks for local verification.

Do not scale.
Use figured dimensions only.
MML Review Set
22 AUG 2022

NOT FOR CONSTRUCTION

THE LINDEN
Michigan Municipal League

Job Number:
2022xx
Title:
BUILDING AND WALL SECTION

A3.0

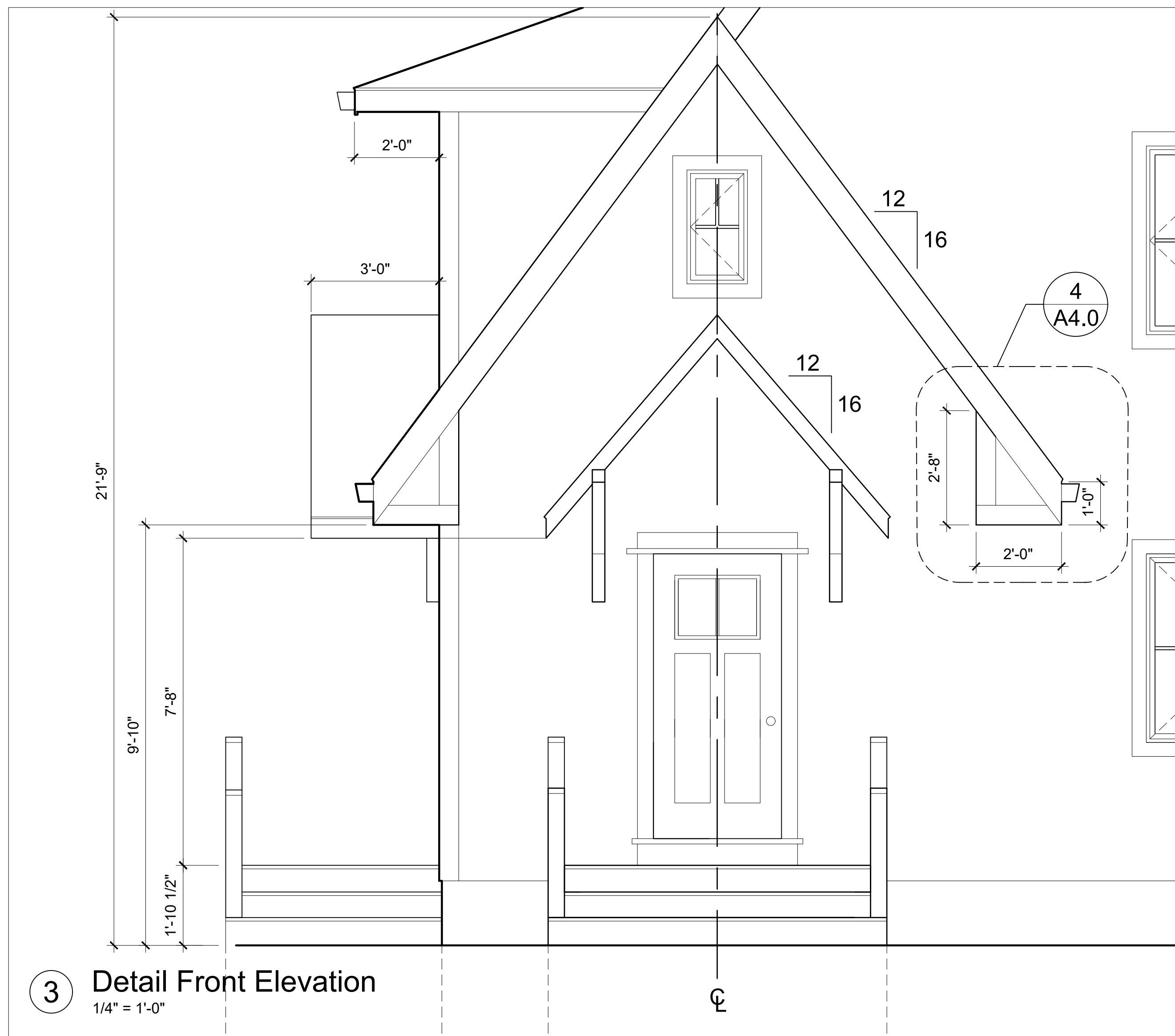

3 Detail Front Elevation
1/4" = 1'-0"

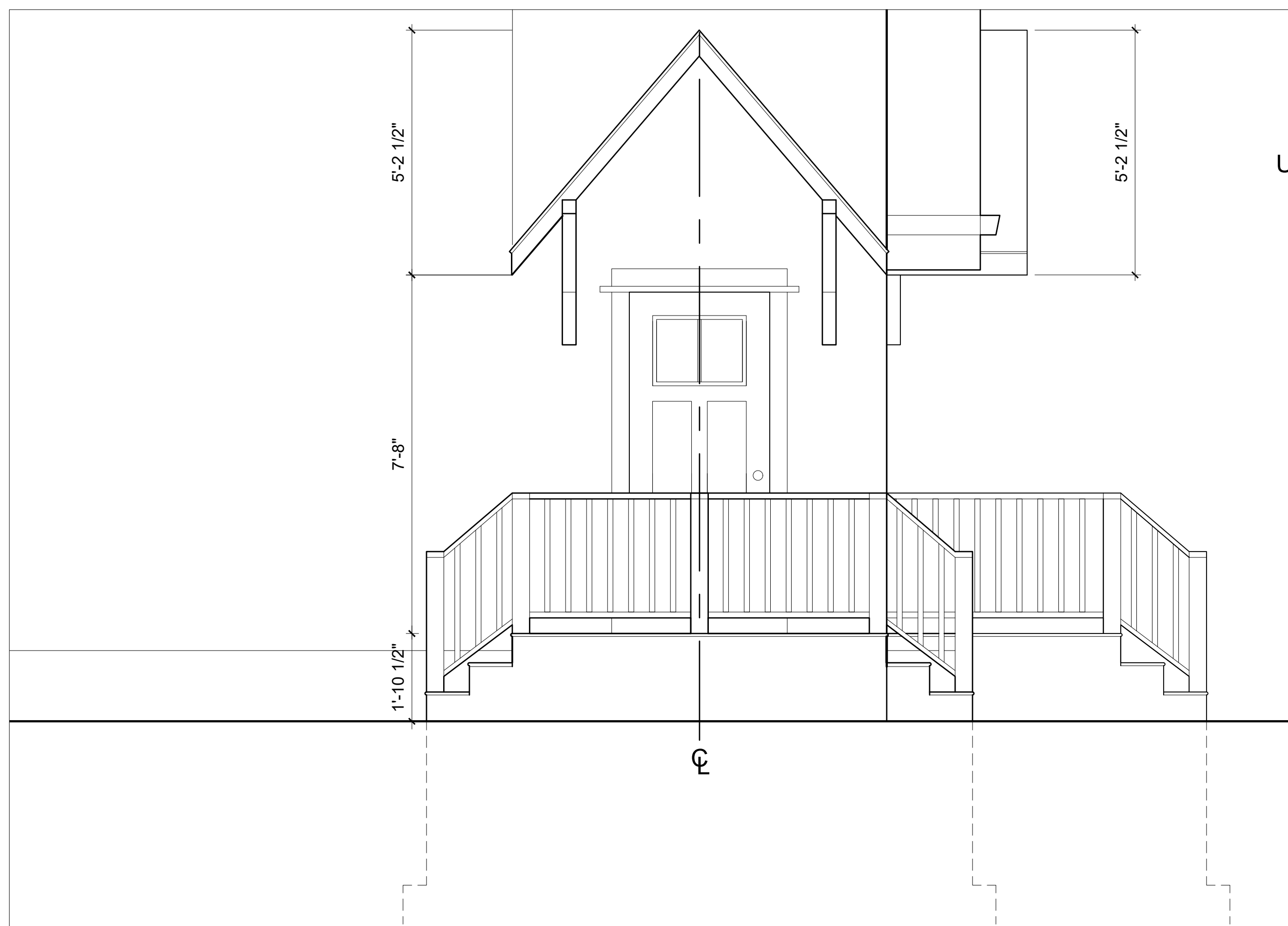

4 Detail Left Elevation
1/4" = 1'-0"

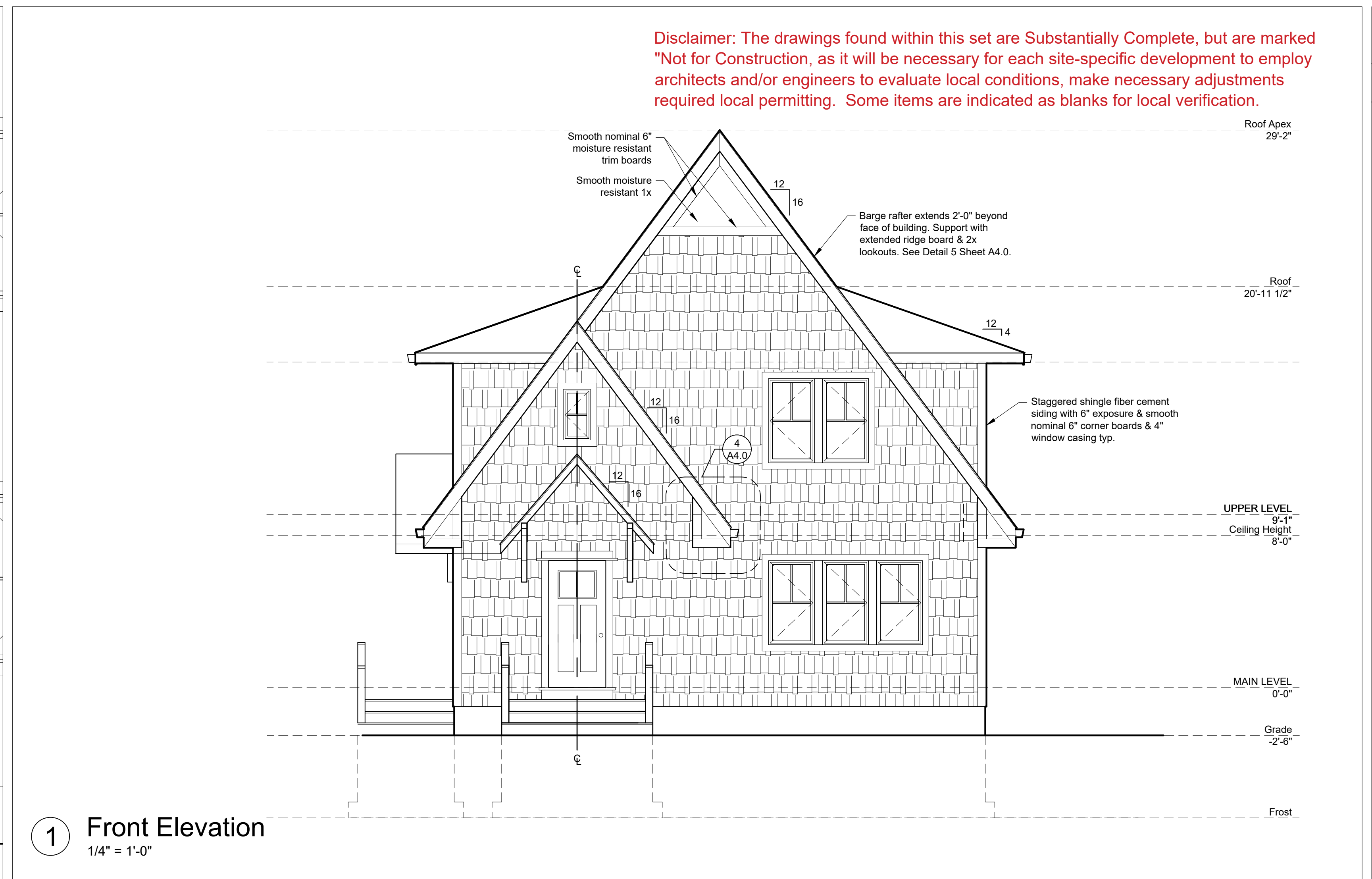

1 Front Elevation
1/4" = 1'-0"

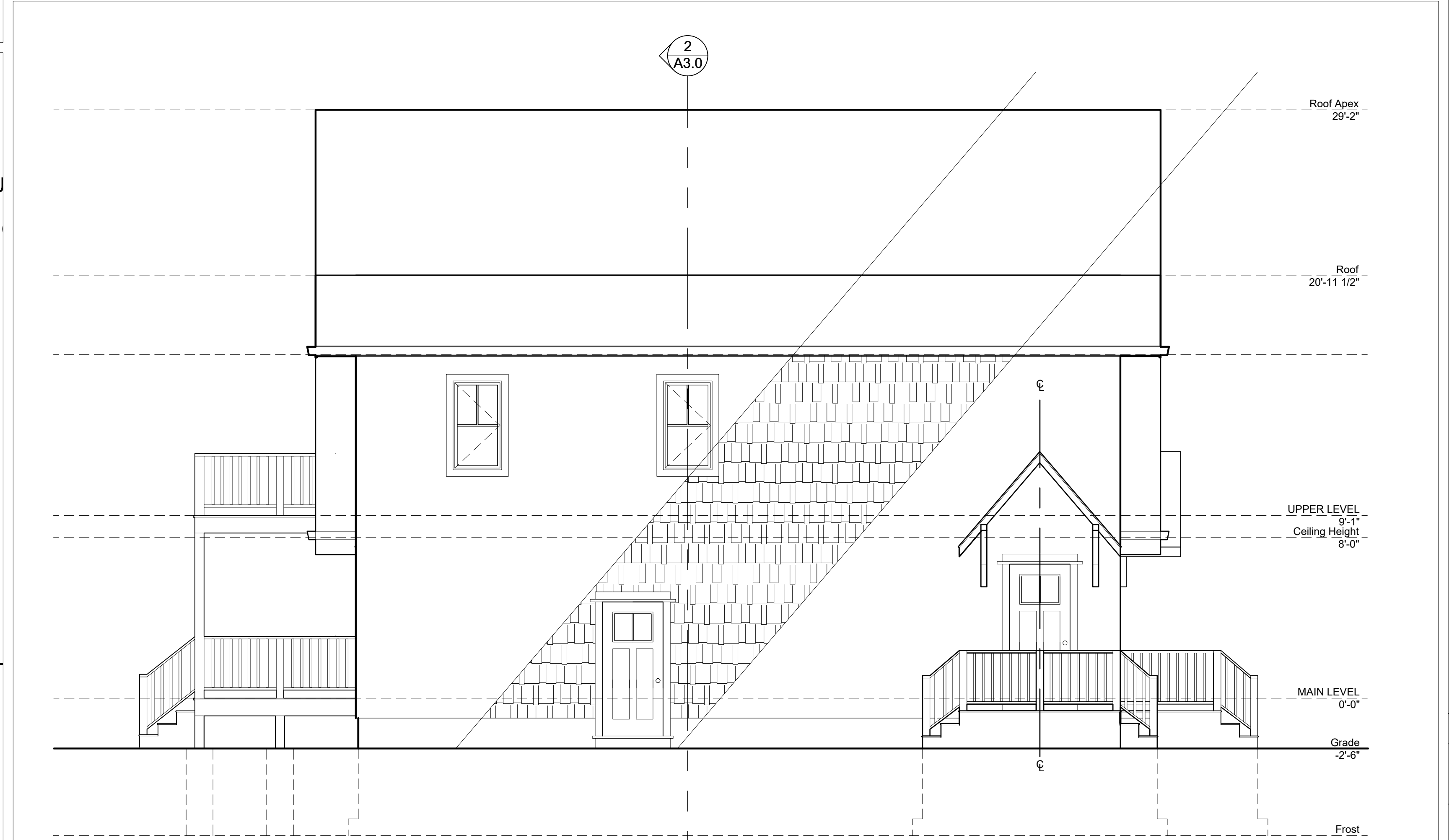

2 Left Elevation
1/4" = 1'-0"

Do not scale.
Use figured
dimensions only.

MML Review Set
22 AUG 2022

NOT FOR CONSTRUCTION

THE LINDEN
Michigan Municipal League

Job Number:
2022xx
Title:
FRONT & RIGHT
ELEVATIONS

A4.0



3 Detail Rear Elevation
1/4" = 1'-0"

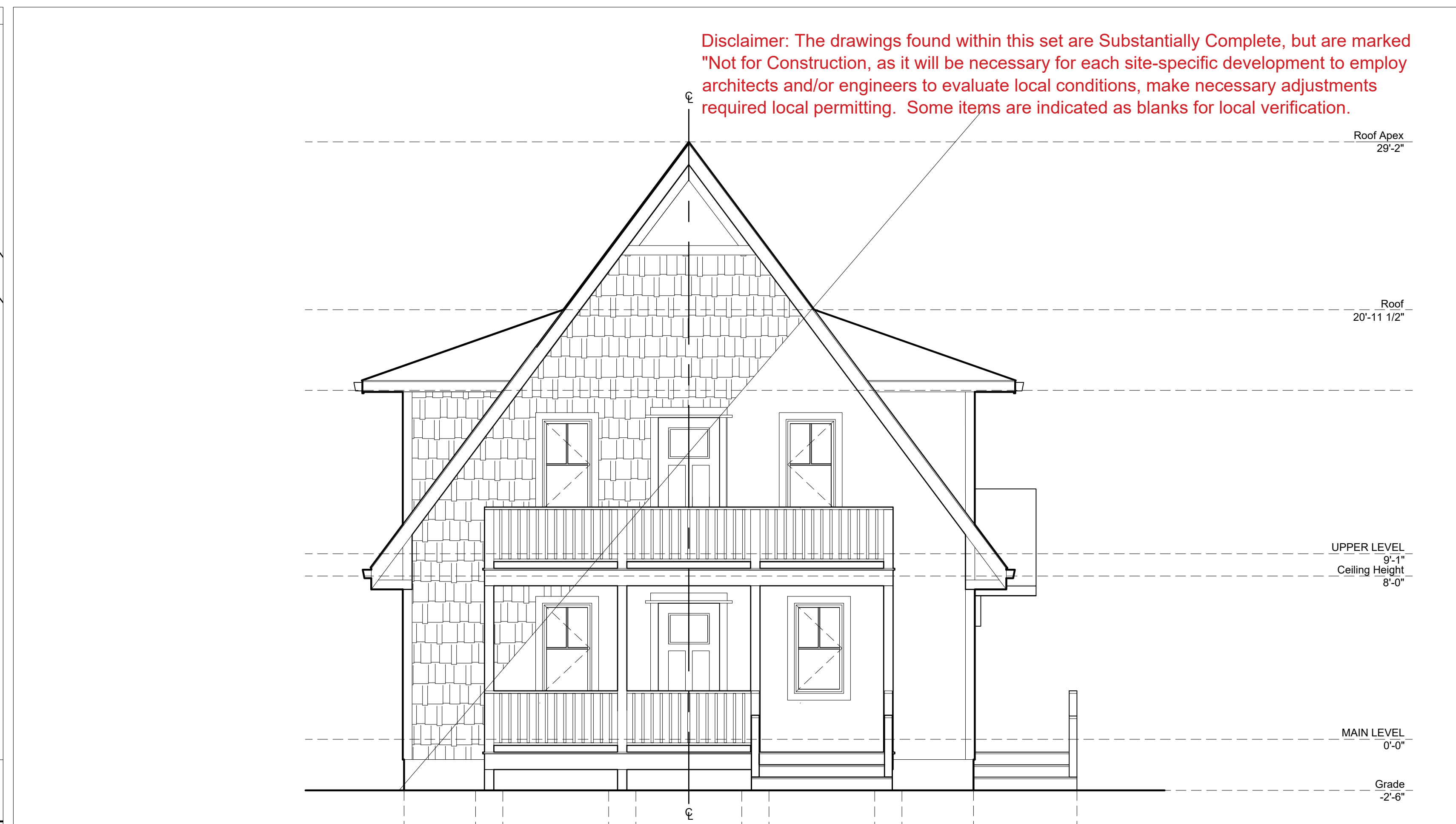

1 Rear Elevation
1/4" = 1'-0"

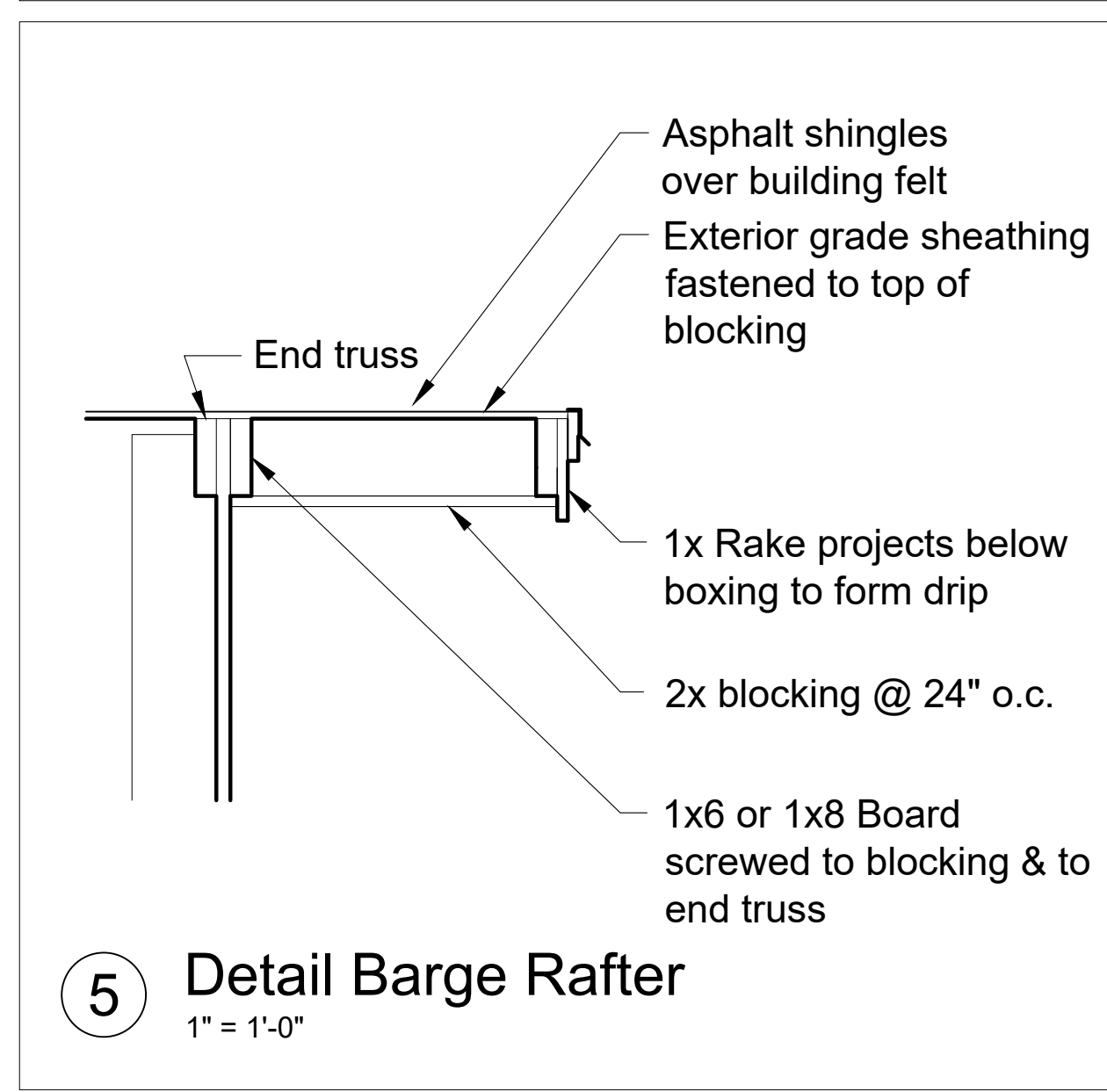

5 Detail Barge Rafter
1" = 1'-0"

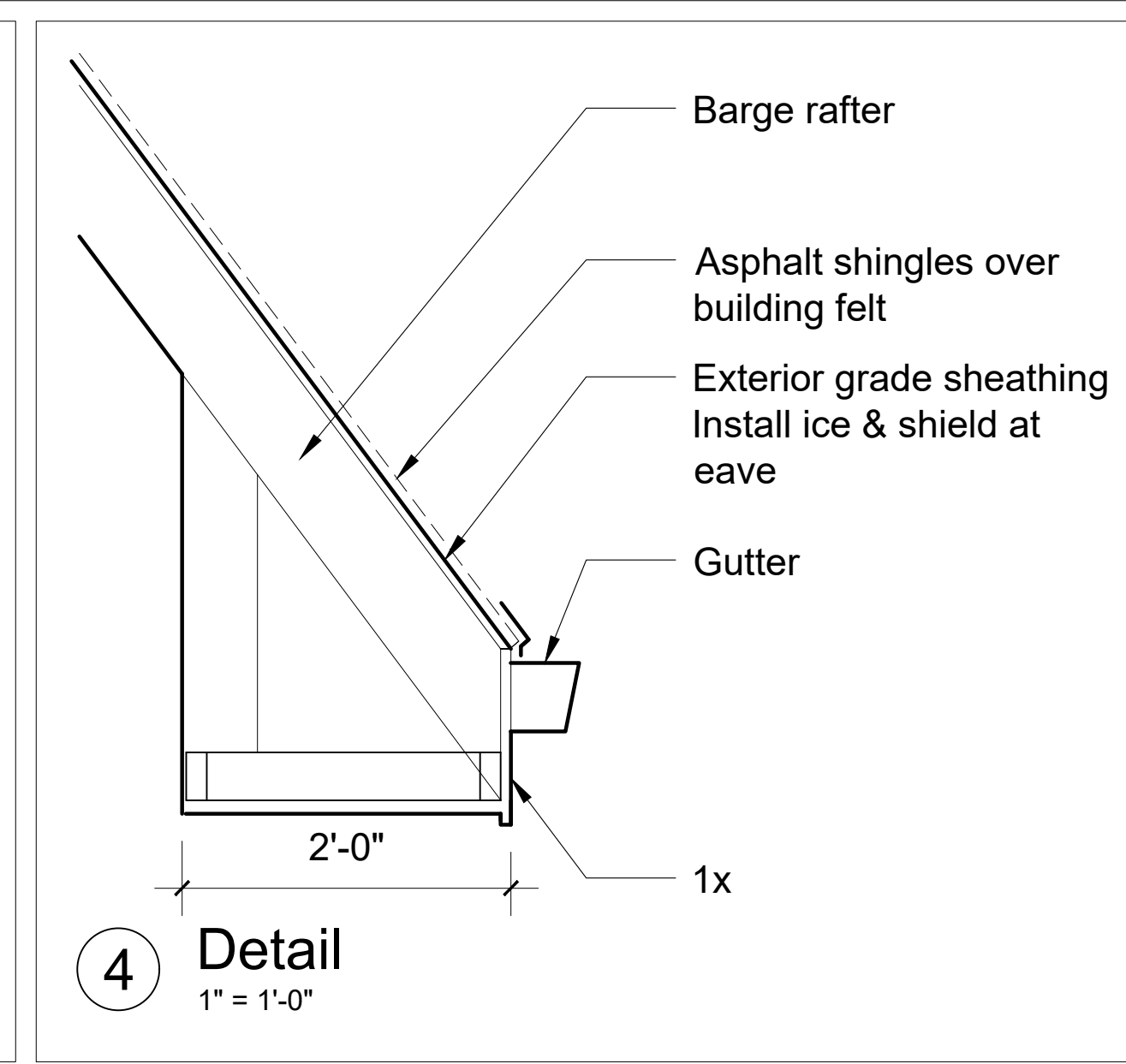

4 Detail
1" = 1'-0"

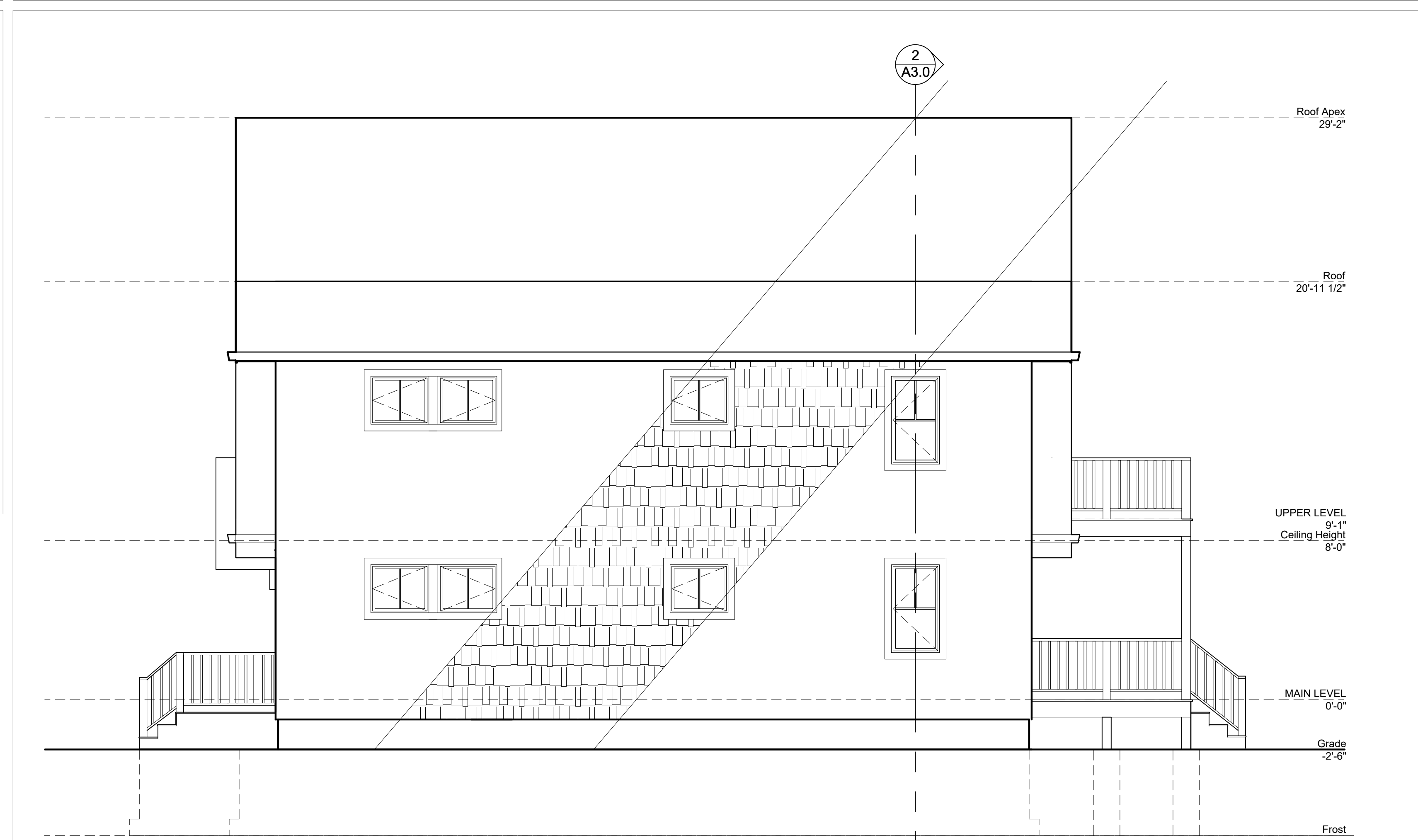

2 Right Elevation
1/4" = 1'-0"

Disclaimer: The drawings found within this set are Substantially Complete, but are marked "Not for Construction, as it will be necessary for each site-specific development to employ architects and/or engineers to evaluate local conditions, make necessary adjustments required local permitting. Some items are indicated as blanks for local verification.

Do not scale.
Use figured dimensions only.
MML Review Set
22 AUG 2022

NOT FOR CONSTRUCTION

THE LINDEN
Michigan Municipal League

Job Number:
2022xx
Title:
FRONT & RIGHT ELEVATIONS

A4.1

Disclaimer: The drawings found within this set are Substantially Complete, but are marked "Not for Construction, as it will be necessary for each site-specific development to employ architects and/or engineers to evaluate local conditions, make necessary adjustments required for local permitting. Some items are indicated as blanks for local verification.

Do not scale.
Use figured dimensions only.

MML Review Set
22 AUG 2022

NOT FOR CONSTRUCTION

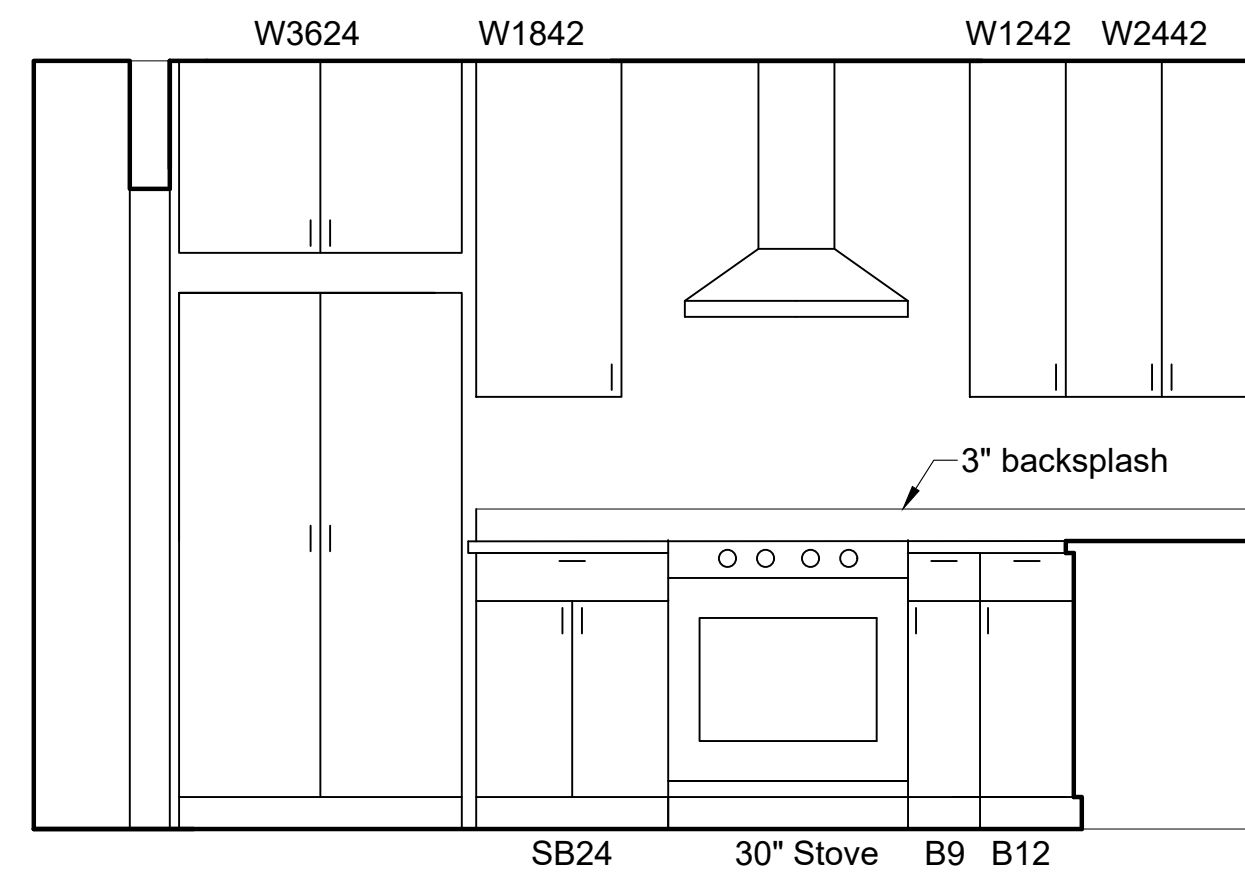

1 Kitchen Elevations - Rear
1/2" = 1'-0"

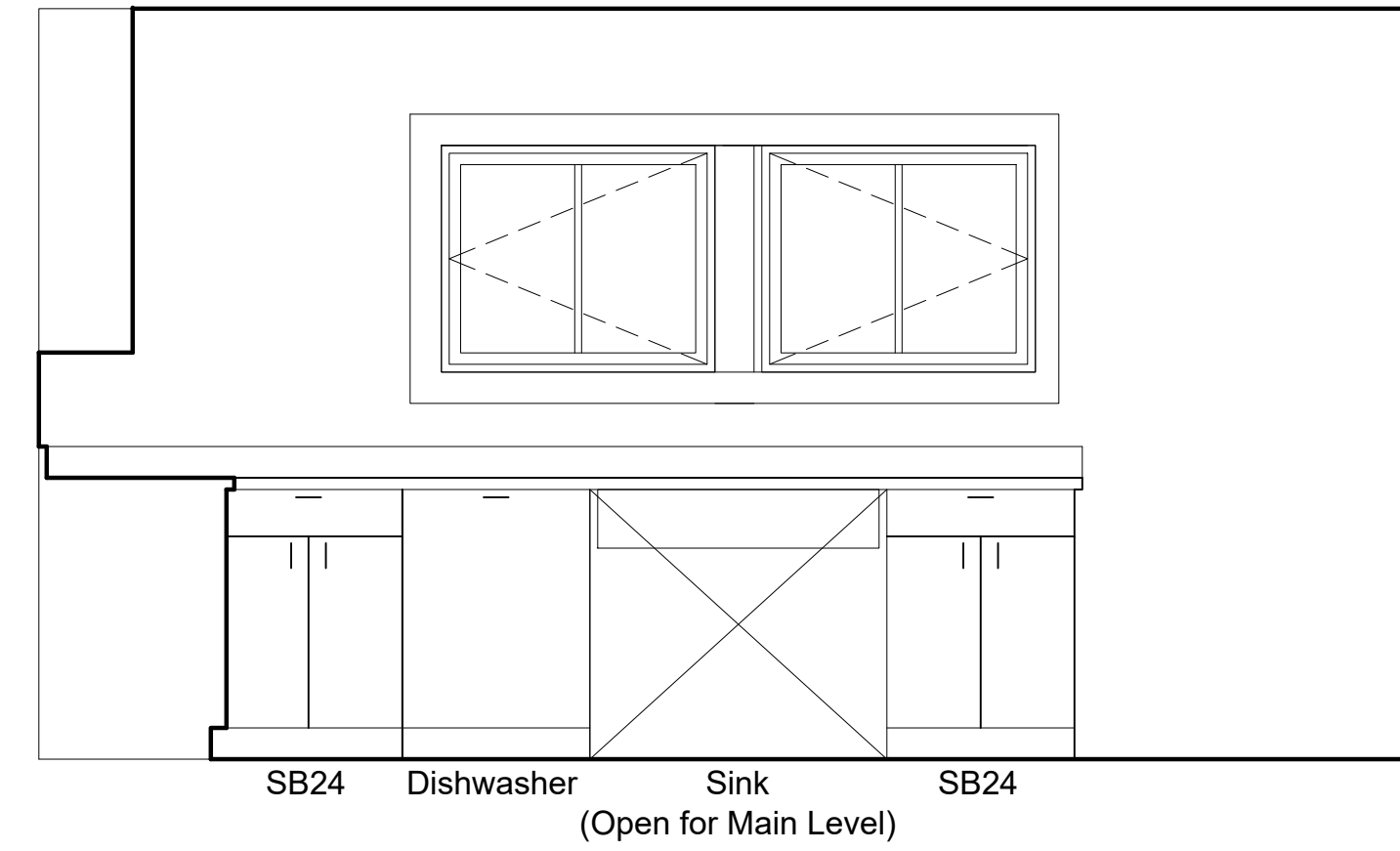

2 Kitchen Elevation
1/2" = 1'-0"

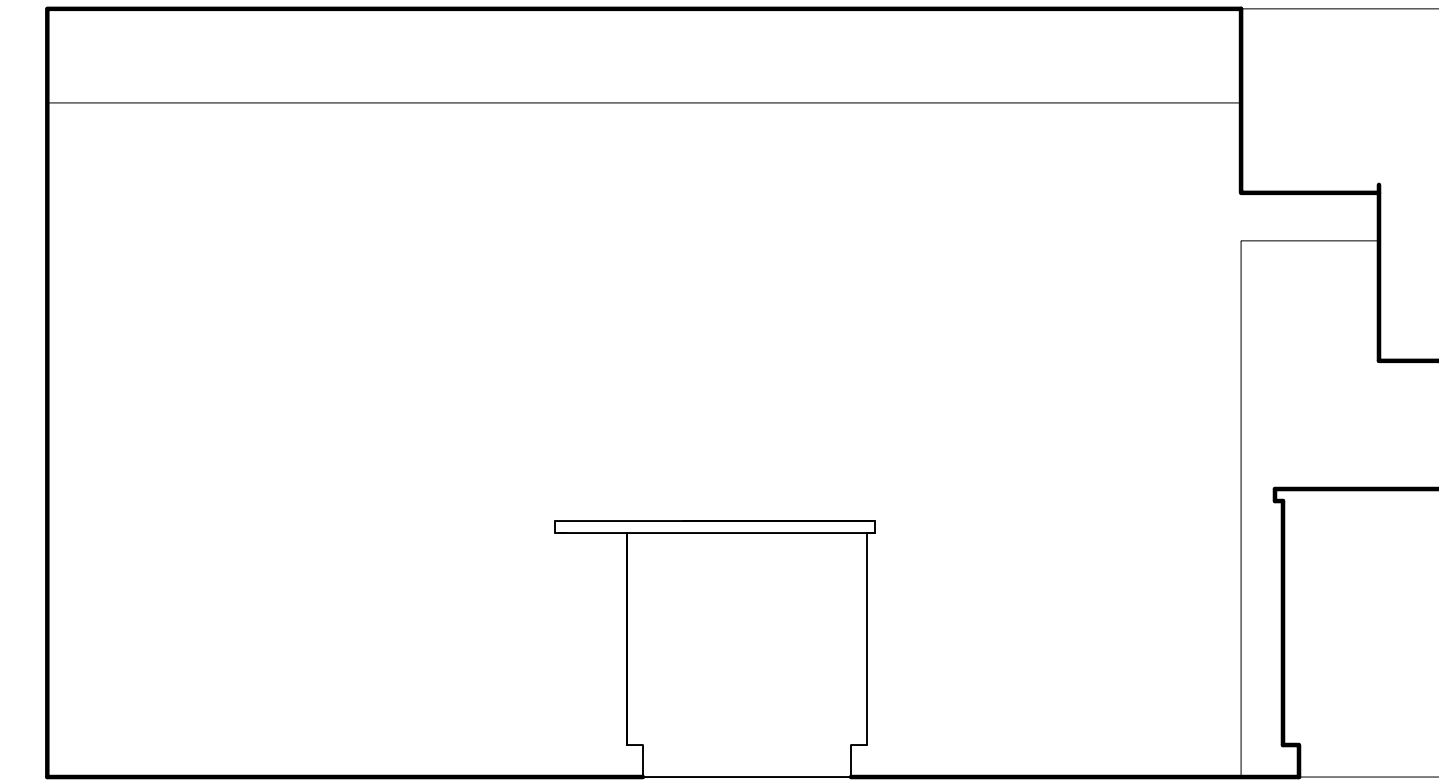

3 Kitchen Elevation
1/2" = 1'-0"

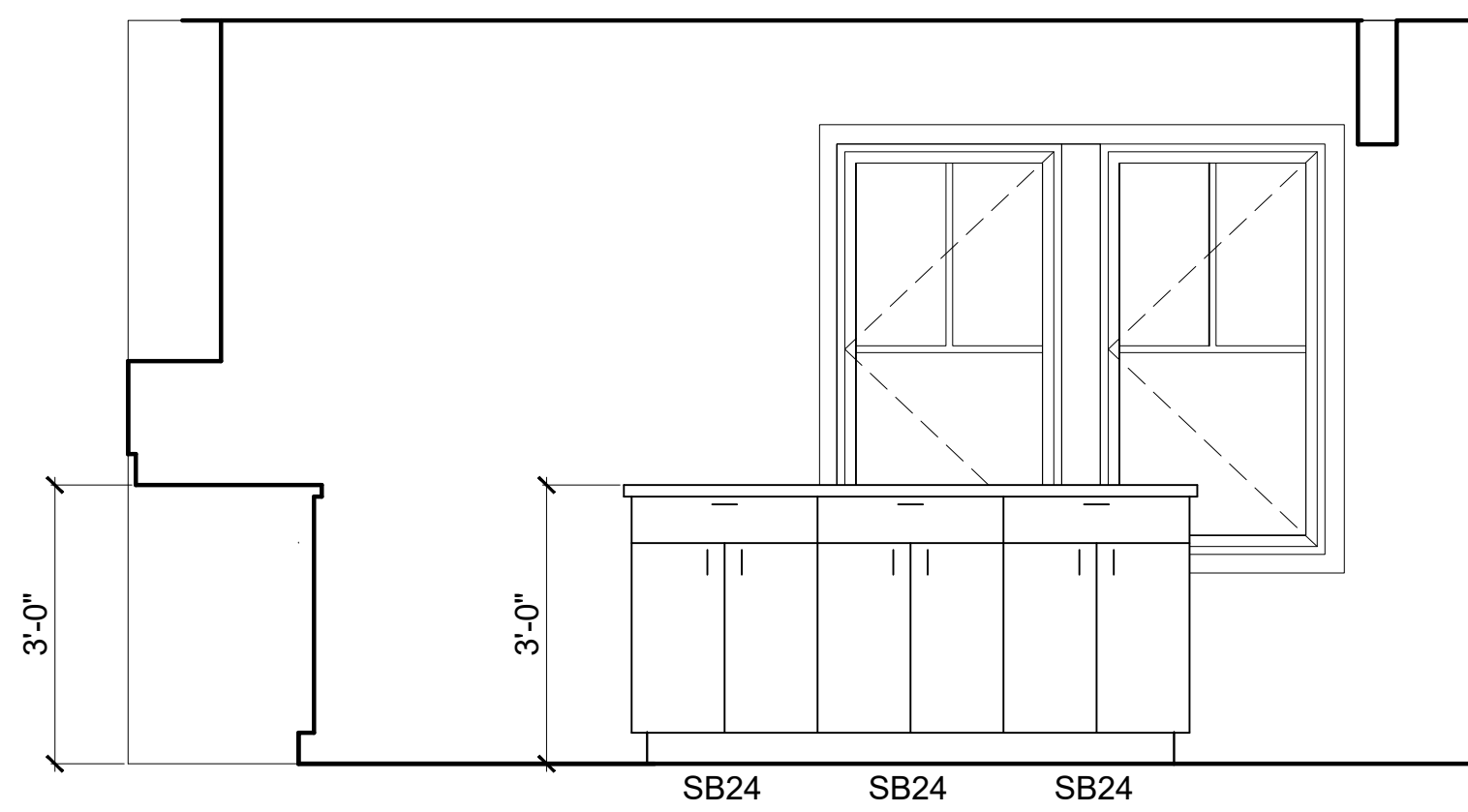

5 Upper Level Kitchen Elevations 1/2" = 1'-0"

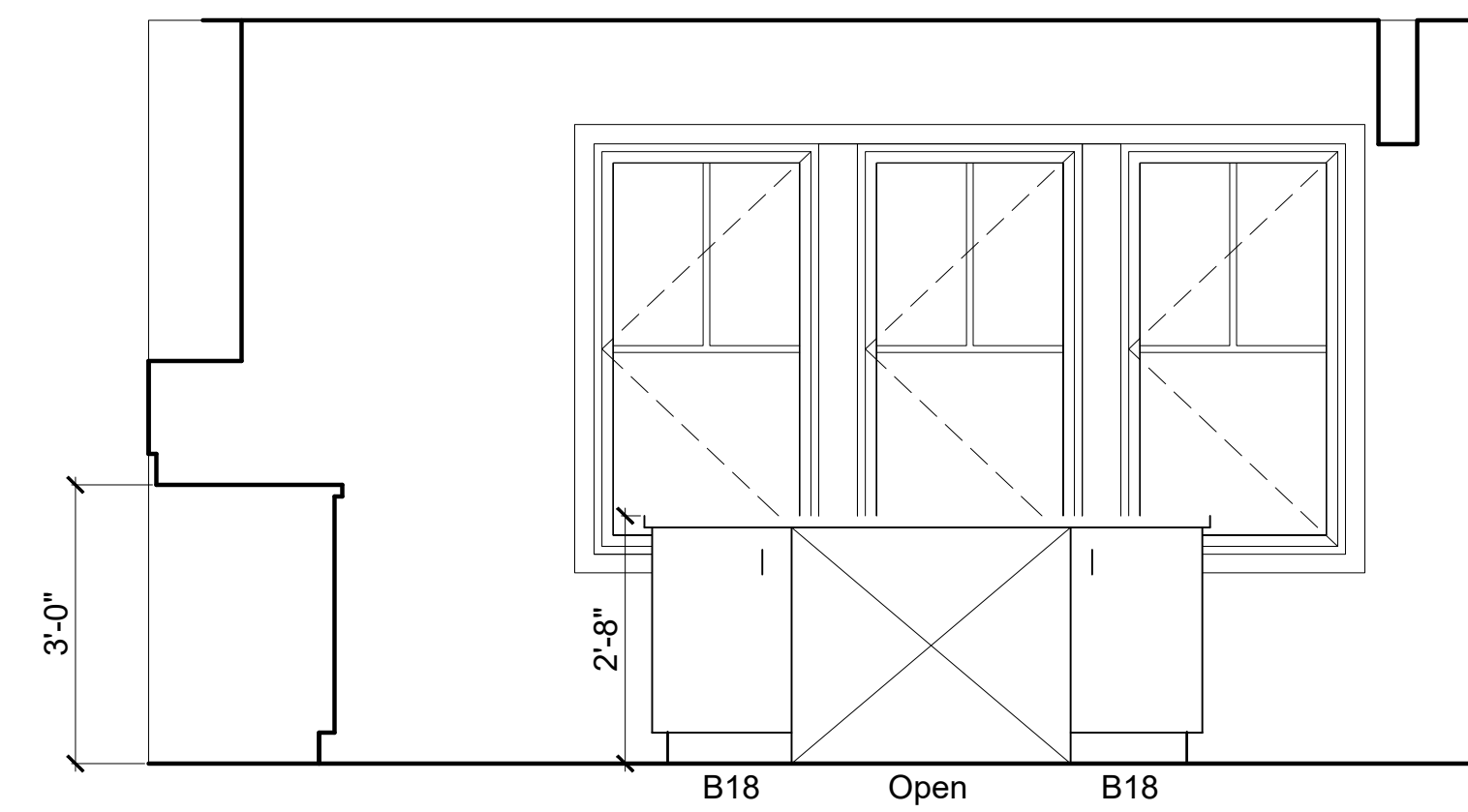

4 Main Level Kitchen Elevations
1/2" = 1'-0"

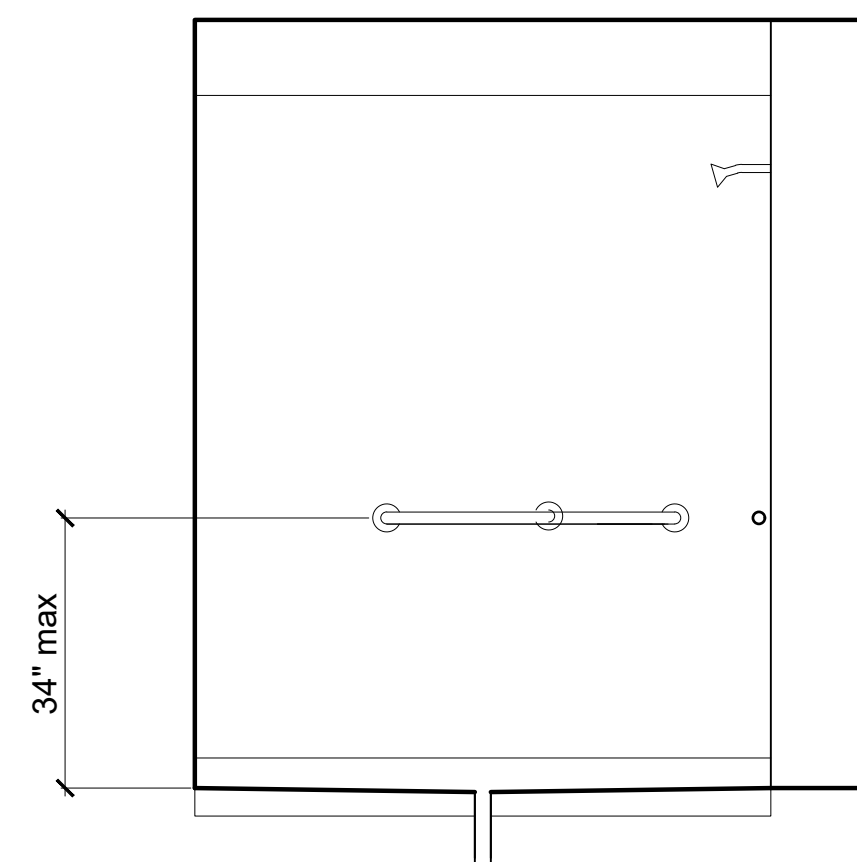

6 Bathroom Elevations
1/2" = 1'-0"

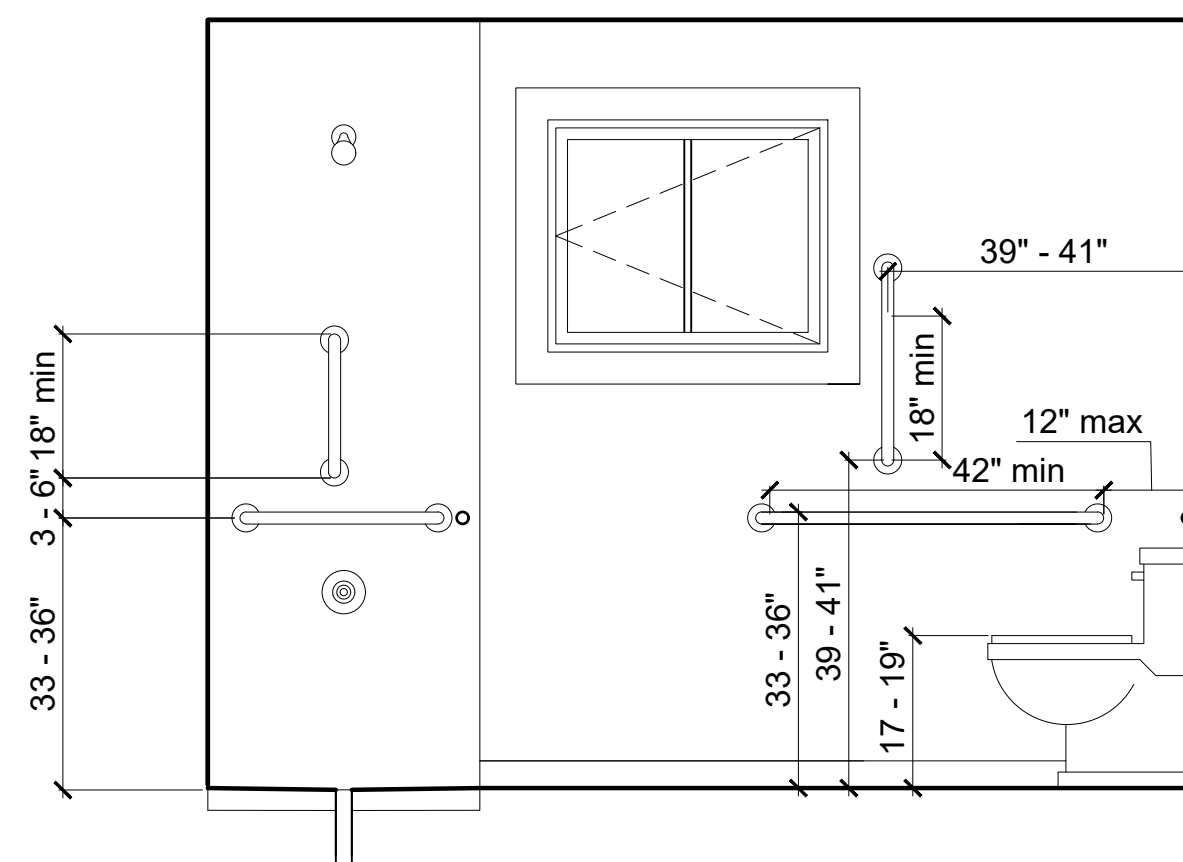

7 Bathroom Elevations
1/2" = 1'-0"

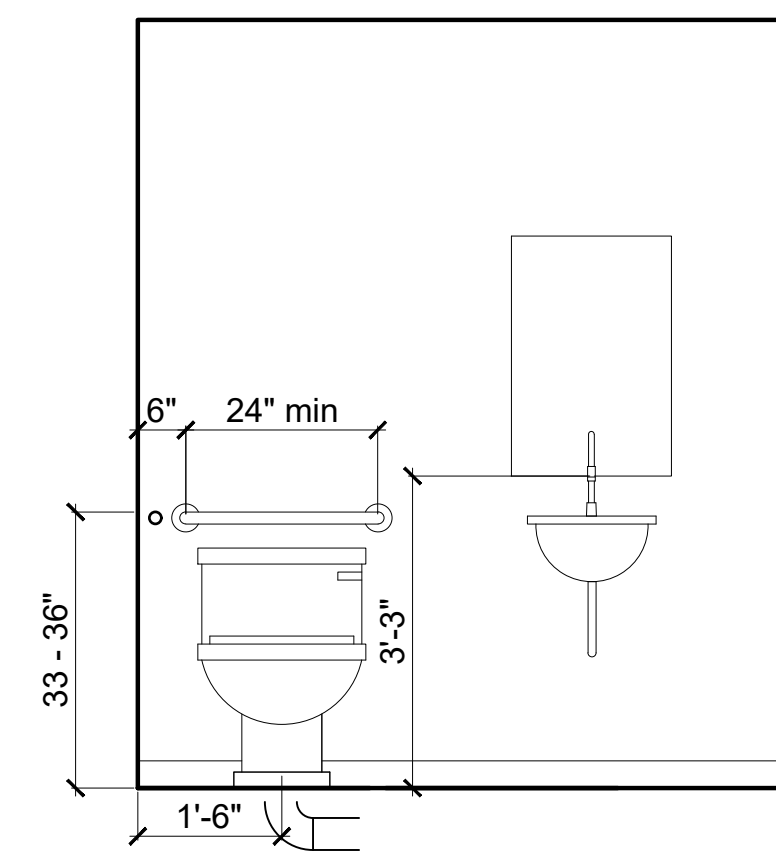

8 Bathroom Elevations
1/2" = 1'-0"

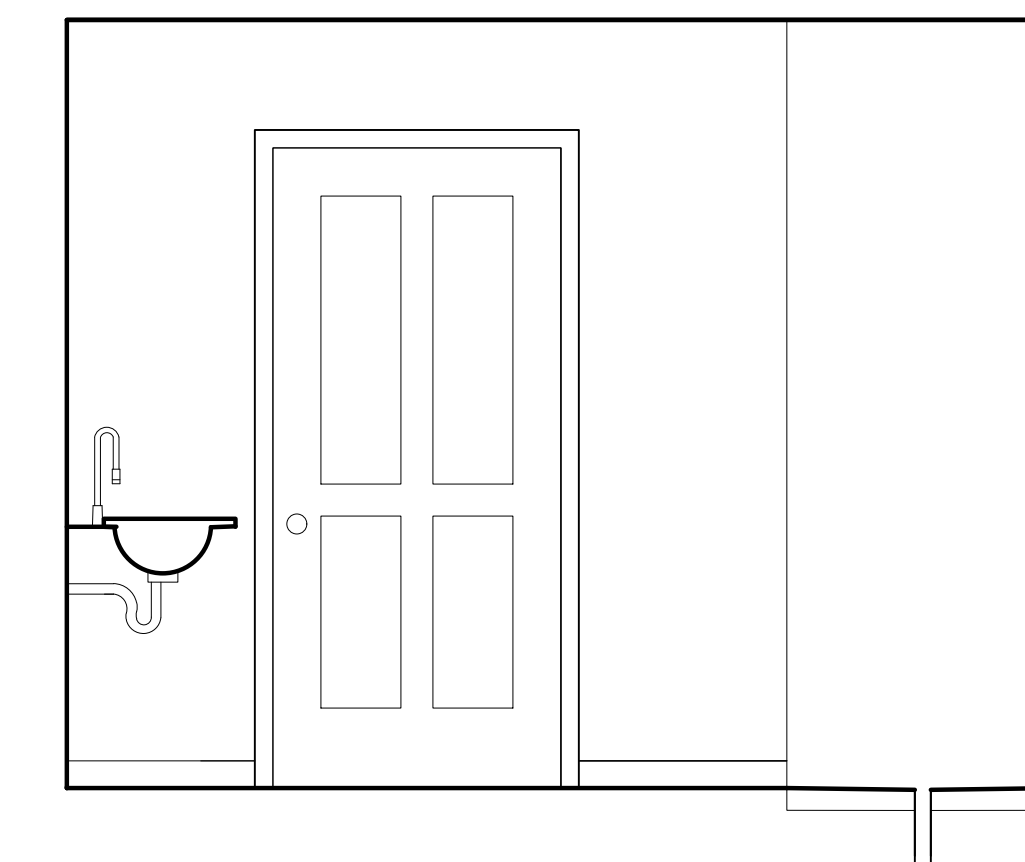

9 Bathroom Elevations
1/2" = 1'-0"

THE LINDEN
Michigan Municipal League

Job Number:
2022xx
Title:
INTERIOR
ELEVATIONS

A5.0

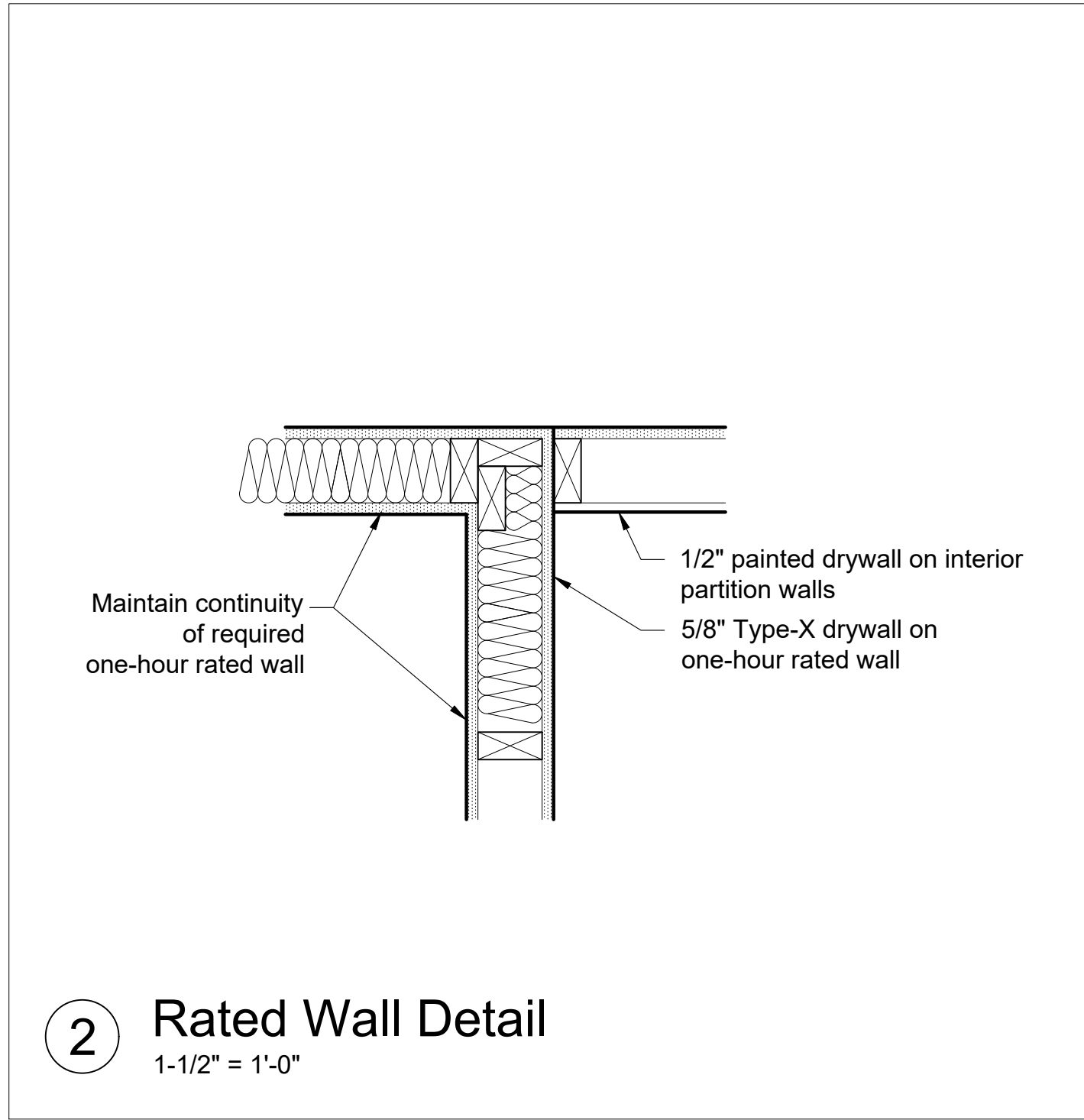

2 Rated Wall Detail
1-1/2" = 1'-0"

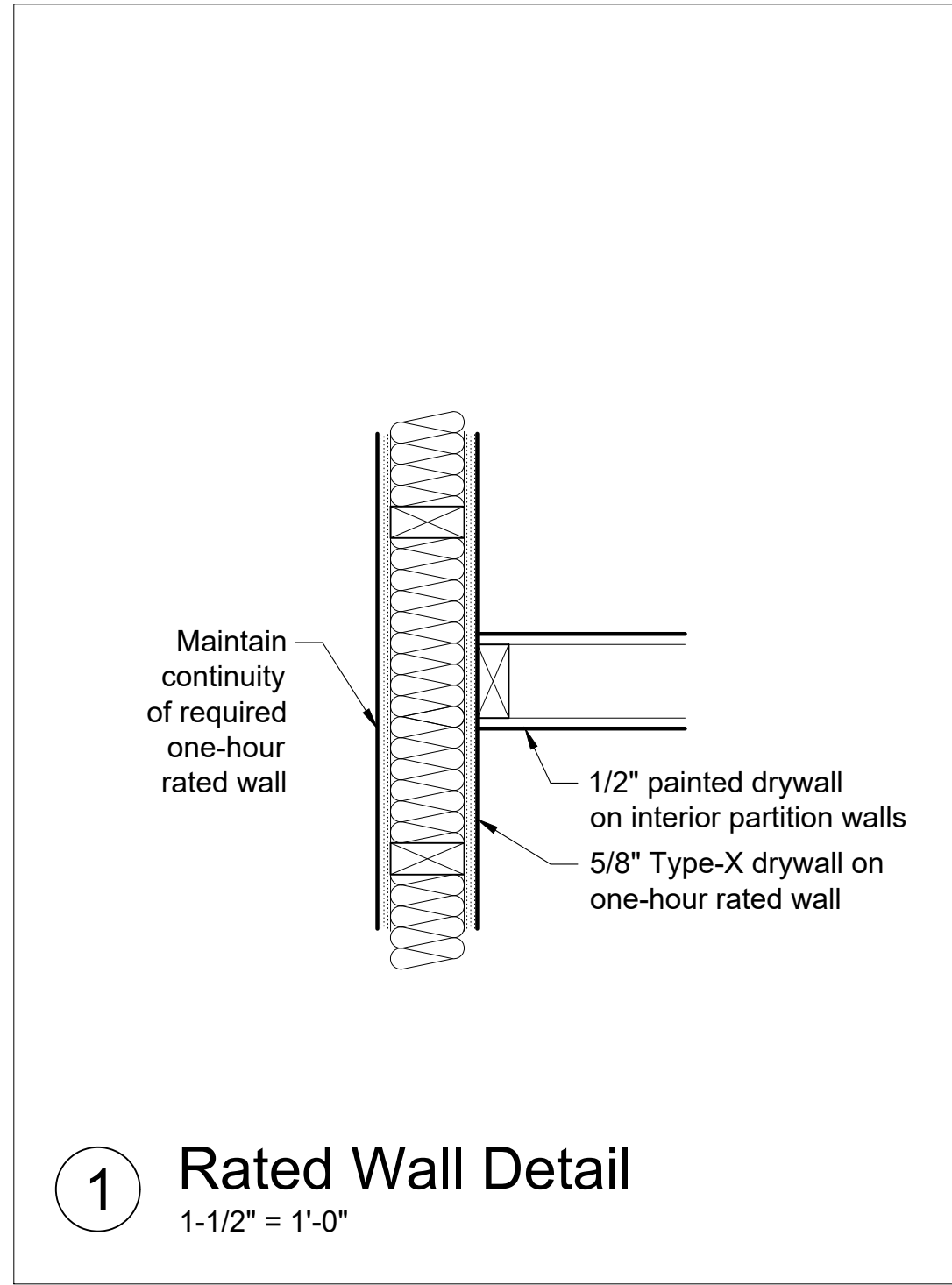

1 Rated Wall Detail
1-1/2" = 1'-0"

Disclaimer: The drawings found within this set are Substantially Complete, but are marked "Not for Construction, as it will be necessary for each site-specific development to employ architects and/or engineers to evaluate local conditions, make necessary adjustments required for local permitting. Some items are indicated as blanks for local verification.

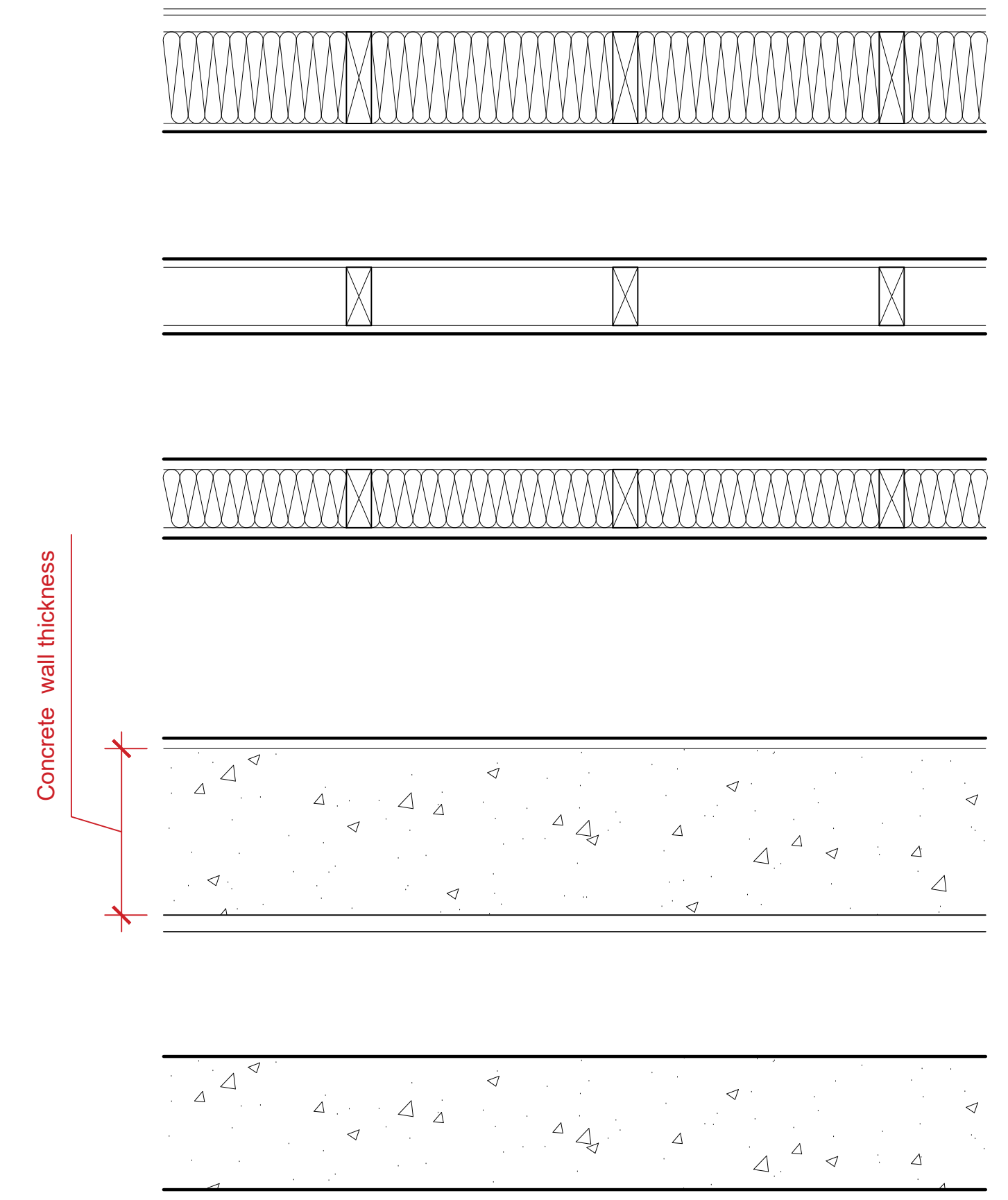

Wall Type #1: Exterior Framed Wall
2x6 wood framing with 1" rigid insulation sheathing and insulation within cavity. Interior finished with vapor diffusion retarder paint over 1/2" drywall.

Wall Type #2: Interior Partition Wall
2x4 wood framing spaced 16" o.c. finished on each side with painted 1/2" drywall.

Wall Type #3: Interior Rated Wall
UL U305: one-hour fire rating. STC 36
2x4 wood studs spaced 16" o.c. with 3-1/2" glass fiber batt insulation and 5/8" thick Type-X gypsum boards on either side.

Wall Type #4: Exterior Foundation Wall
Reinforced concrete with exterior dampproofing and interior rigid insulation.

Wall Type #5: Interior Foundation Wall
Reinforced concrete

3 Wall Details
1-1/2" = 1'-0"

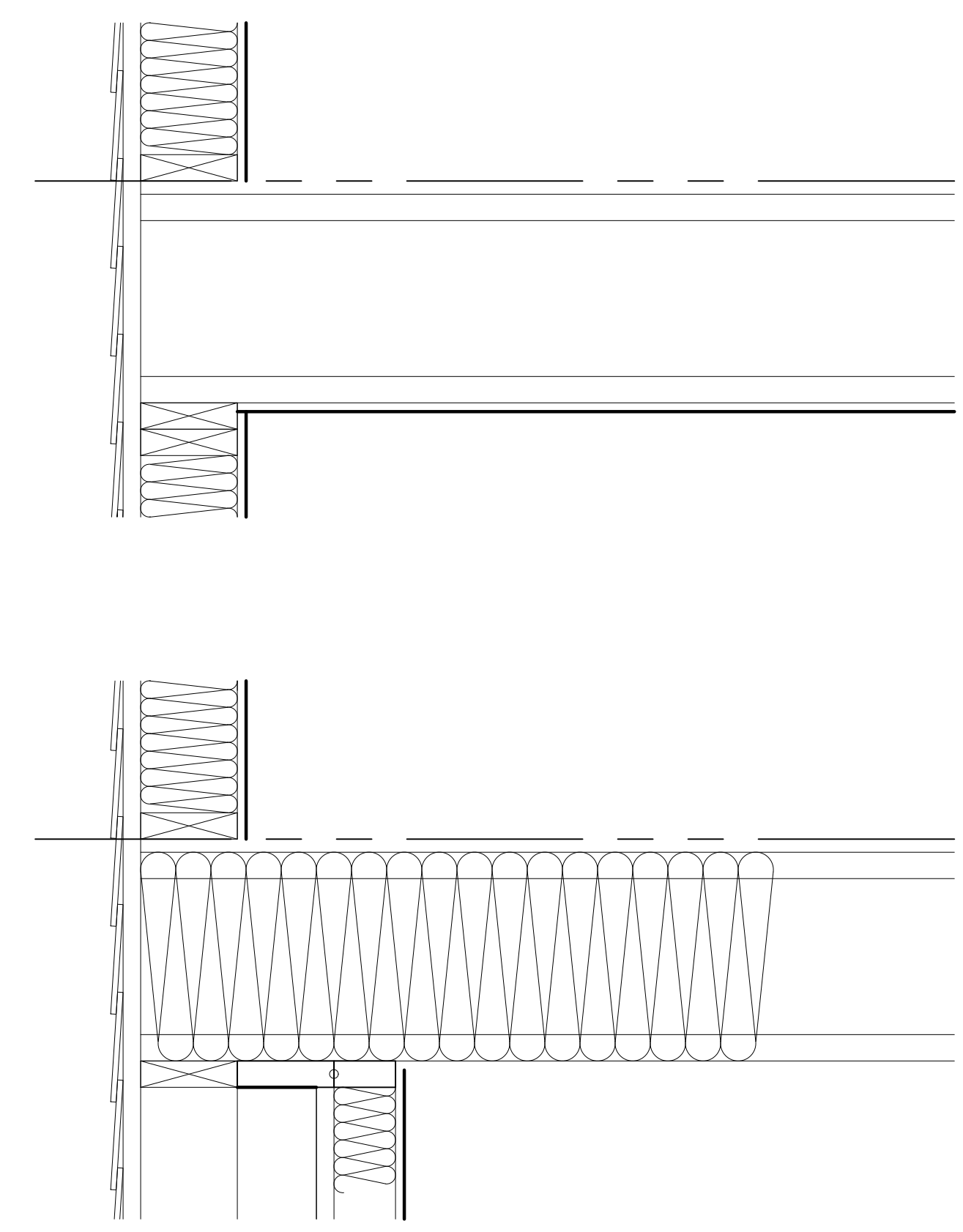

Upper Floor Assembly
ASTM E119: One hour. Finish flooring on 3/4" T&G plywood subfloor over 11 - 7/8" TJI wood joist spaced at 16" o.c. Underside of TJI wood joist finished with 5/8" Type-x gypsum wall board, primed and painted

Main Floor Assembly
Finish flooring on 3/4" T&G plywood subfloor over 11 - 7/8" TJI wood joist spaced at 16" o.c.

4 Floor Details
1-1/2" = 1'-0"

Do not scale. Use figured dimensions only.
MML Review Set
22 AUG 2022

NOT FOR CONSTRUCTION

THE LINDEN
Michigan Municipal League

Job Number:
2022xx
Title:
INTERIOR
DETAILS

A6.0

NOT FOR CONSTRUCTION

THE LINDEN
Michigan Municipal League

Disclaimer: The drawings found within this set are Substantially Complete, but are marked "Not for Construction, as it will be necessary for each site-specific development to employ architects and/or engineers to evaluate local conditions, make necessary adjustments required for local permitting. Some items are indicated as blanks for local verification.

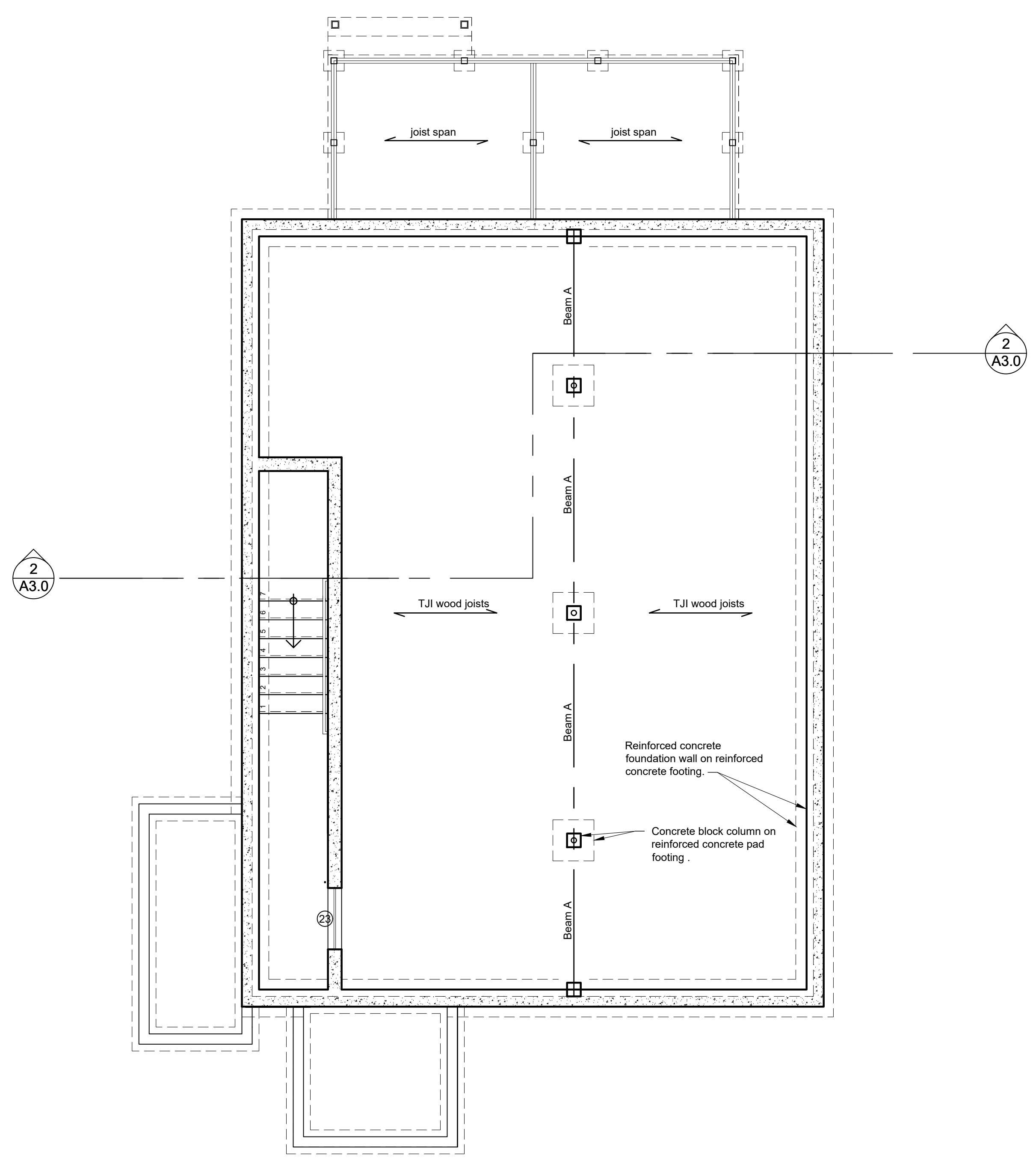

1 Foundation Plan
1/4" = 1'-0"

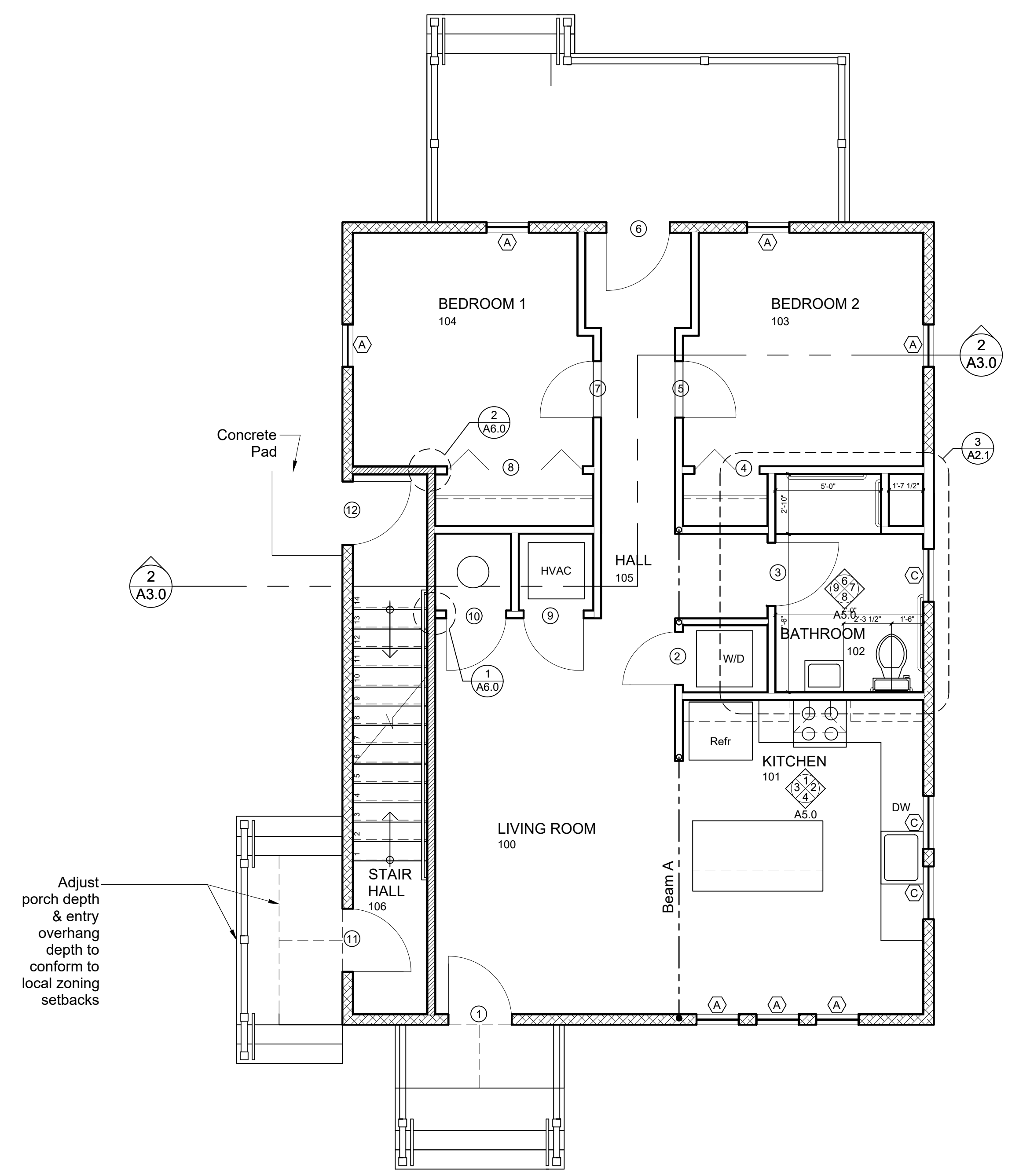

1 Main Plan
1/4" = 1'-0"



SIDING

Option 1 Staggered shingle fiber cement siding with 6" exposure

Option 2 Staggered cedar shakes

CORNER BOARDS

Option 1 Smooth nominal 6" cement fiber boards

Option 2 Smooth nominal 6" Cedar boards

DETAILS

Option 1 Smooth moisture resistant 1x trim boards

Option 2 Cedar 1x trim boards



SIDING

Option 1 Cement fiber board lap siding

Option 2 Cedar lap siding

CORNER BOARDS

Option 1 Smooth nominal 6" cement fiber boards

Option 2 Smooth nominal 6" Cedar boards

DETAILS

Option 1 Smooth moisture resistant 1x trim boards

Option 2 Cedar 1x trim boards



SIDING

Option Stucco

CORNER BOARDS

Option 1 Smooth nominal 6" cement fiber boards

Option 2 Smooth nominal 6" Cedar boards

DETAILS

Option 1 Smooth moisture resistant 1x trim boards

Option 2 Cedar 1x trim boards

Disclaimer: The drawings found within this set are Substantially Complete, but are marked "Not for Construction, as it will be necessary for each site-specific development to employ architects and/or engineers to evaluate local conditions, make necessary adjustments required for local permitting. Some items are indicated as blanks for local verification.

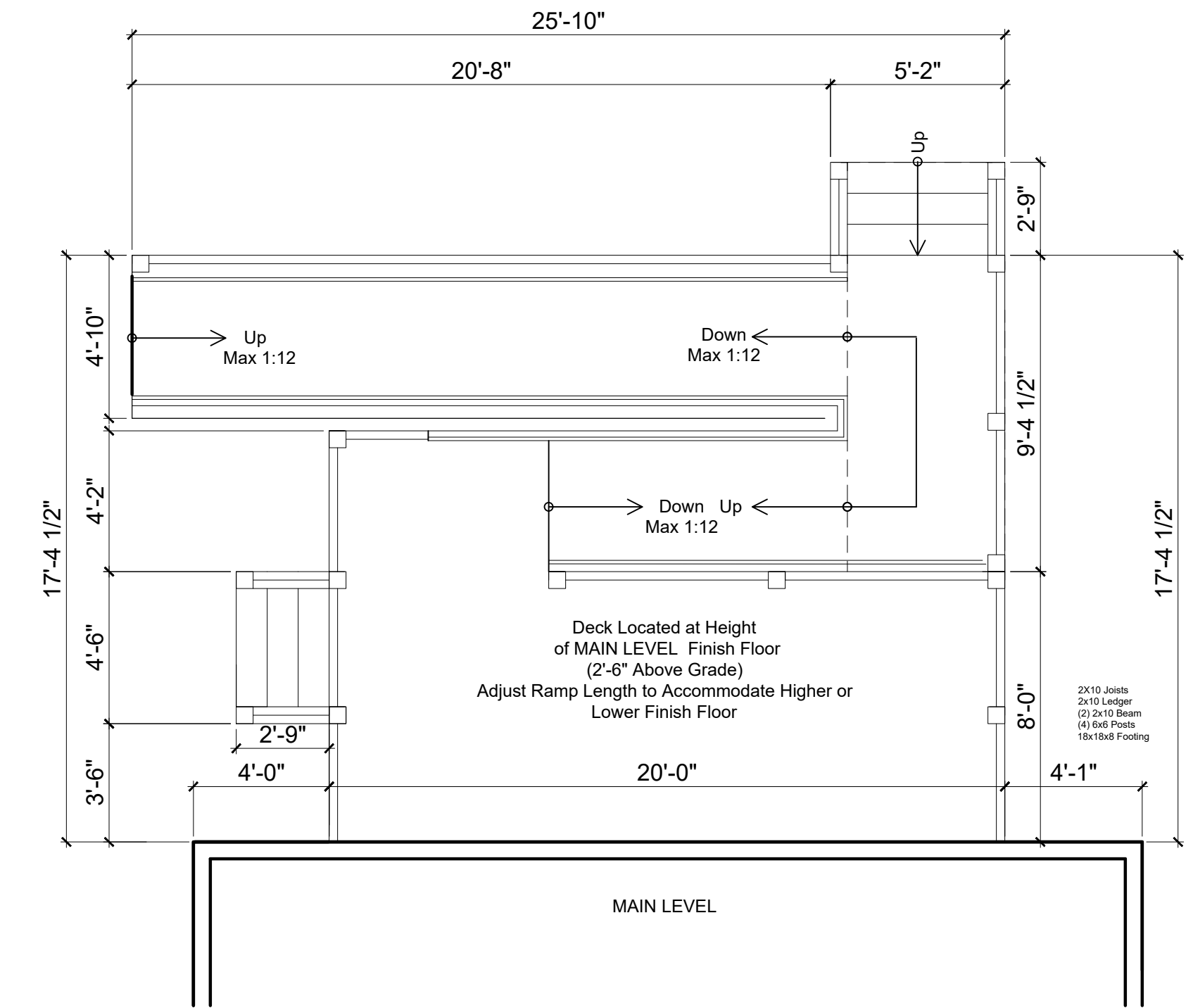

1 Schematic Rear Ramp
3/32" = 1'-0"

2 Exterior Finish Material Options

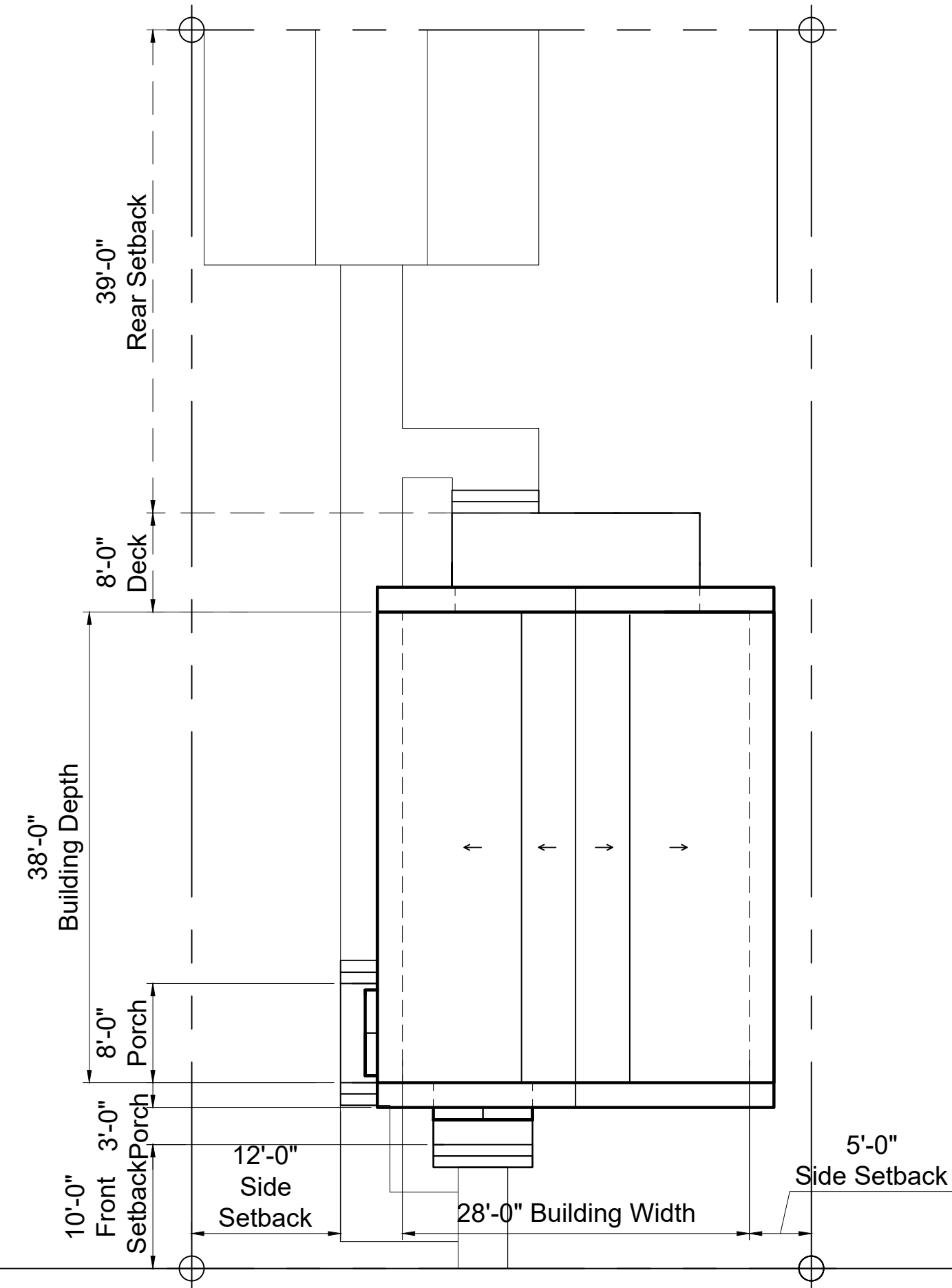

5 Site Plan - Alley Access
3/32" = 1'-0"

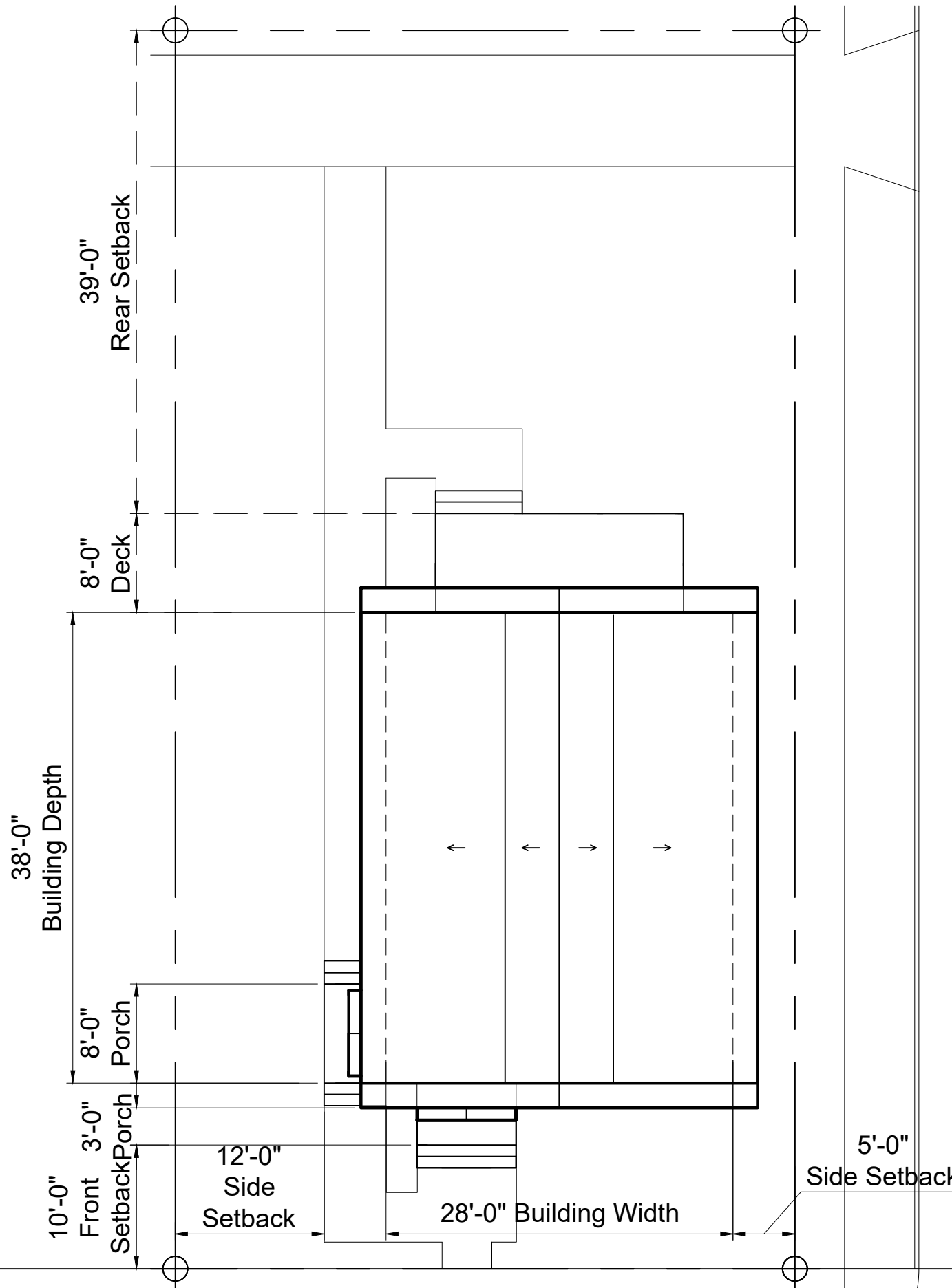

4 Site Plan - Corner
3/32" = 1'-0"

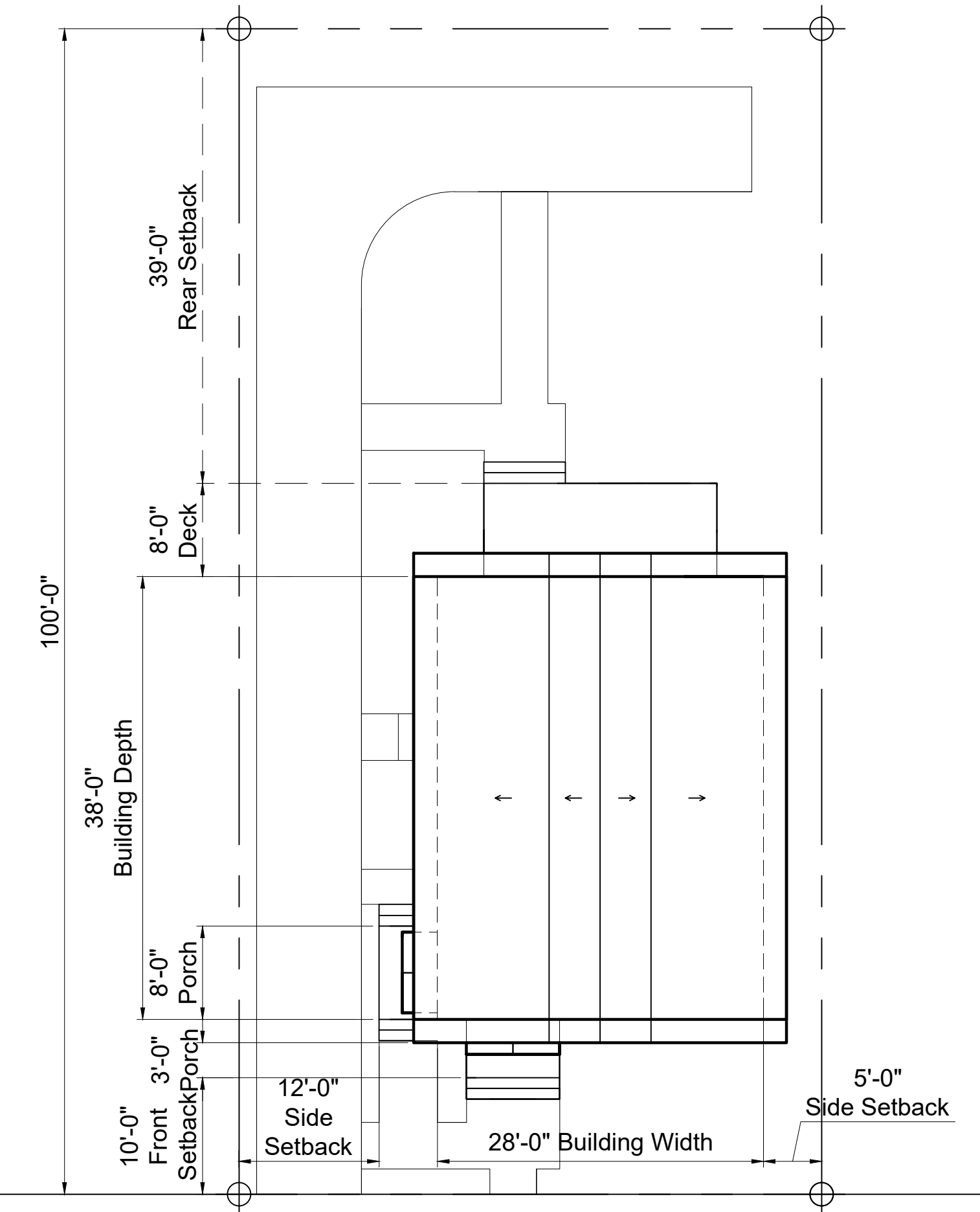

3 Site Plan - Standard Lot
3/32" = 1'-0"

NOT FOR CONSTRUCTION

THE LINDEN
Michigan Municipal League

ABBREVIATIONS

A, AMP	AMPERES
AF	AMP FUSE OR AMP FRAME
AFC	AVAILABLE FAULT CURRENT (SYMMETRICAL)
A.F.F.	ABOVE FINISHED FLOOR
AIC	AMPERE INTERRUPTING CAPACITY
AM	AMMETER
ASYM.	ASYMMETRICAL
AT	AMP TRIP
ATS	AUTOMATIC TRANSFER SWITCH
AWG	AMERICAN WIRE GAUGE
CAP	CONDUIT
CAP	CAPACITY OR CAPACITOR
CATV	COMMUNITY ANTENNA TELEVISION
CB	CIRCUIT BREAKER
CCTV	CLOSED CIRCUIT TELEVISION
CKT, CCT	CIRCUIT
C.O.	CONDUIT ONLY
CONN.	CONNECT OR CONNECTION
CU	COPPER
DA	DURESS ALARM
DB	DOOR BELL
DISC.	DISCONNECT
DPST	DOUBLE POLE SINGLE THROW
EC	ELECTRICAL CONTRACTOR
EWC	ELECTRIC WATER COOLER (COORDINATE ACCESSIBILITY OF GFCI)
ELEC	ELECTRIC OR ELECTRICAL
ELEV	ELEVATION OR ELEVATOR
EMERG.	EMERGENCY
EMERG. EM	EMERGENCY POWER OFF
EPO	ELECTRICAL METAL TUBING
EMT	FIXTURE
FIXT.	FULL LOAD AMPERES
FLA	FLUORESCENT
FLOOR	GALVANIZED RIGID CONDUIT
GRC, GCR	GENERATOR
GEN	GROUND FAULT CIRCUIT INTERRUPTER
GFCI	GROUND FAULT INTERRUPTER
GFI	GROUND
GRD, GND, G	HIGH INTENSITY DISCHARGE
HID	HAND-OFF-AUTO
HOA	HORSEPOWER
HP	HIGH PRESSURE SODIUM
HPS	HERTZ
HZ	INTERMEDIATE METAL CONDUIT
IMC	ISOLATED GROUND
I.G.	INCANDESCENT
INCAND.	JUNCTION BOX
JB	THOUSAND AMPERE INTERRUPTING CAPACITY
KAIC	KILOVOLT AMPERES
KVA	KILOWATT
KW	KILOWATT HOUR
KWH	LIGHTING
LTG	LOW VOLTAGE
LV	MASTER ANTENNA TELEVISION
MATV	MAIN CIRCUIT BREAKER
MCB	MOTOR CONTROL CENTER
MCC	MANHOLE, METAL HALIDE OR MOUNTING HEIGHT
MH	MAIN LUGS ONLY
MLO	NORMALLY CLOSED
N.C.	NATIONAL ELECTRICAL CODE
N.E.C.	NOT IN CONTRACT
N.I.C.	NON FUSIBLE
NF	NORMALLY OPEN
N.O.	NOT TO SCALE
NTS	OVERLOADS
OL	POLE
P	PULLBOX
PB	PHASE
PH OR Ø	PANEL
PNL	PAIR
PR	POLYVINYL CHLORIDE
PVC	POWER
PWR.	RECEPTACLE
REC	RIGID GALVANIZED STEEL
RGS	SOLENOID
SOL	SINGLE POLE DOUBLE THROW
SPDT	SPEAKER
SPKR	SINGLE POLE SINGLE THROW
SPST	SWITCH
SW	SWITCHBOARD
SWBD	SYMMETRICAL
SYM	TELEPHONE
TEL	TRANSFORMER
XFMR	TELEPHONE TERMINAL BACKBOARD
TTB	TELEVISION
TV	TYPICAL
TYP	UNDERGROUND
UG	UNLESS OTHERWISE NOTED
UON	VOLT
V	VOLT AMPERES
VA	VOLTAGE DROP
VD	VOLT METER
VM	WATTS OR WIRE
WM	WITH
W	WITHOUT
W/O	WEATHERPROOF
WP	EXPLOSION PROOF
XP	

CIRCUIT DESIGNATIONS

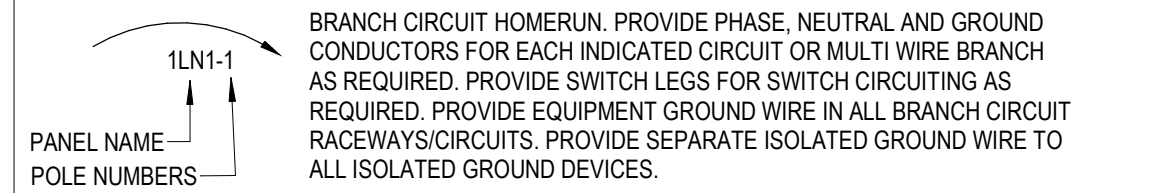

CONDUIT SIZE	MAX QUANTITY OF CONDUCTORS PER CONDUIT		
	CONDUCTOR SIZE		
1/2 INCH	1 TO 4	1 TO 4	NA
3/4 INCH	5 TO 8	5 TO 8	1 TO 3
1 INCH	9 TO 13	7 TO 11	4 TO 5

SEE SPECIFICATIONS FOR LIMITATIONS ON QUANTITY OF CURRENT CARRYING CONDUCTORS PER CONDUIT

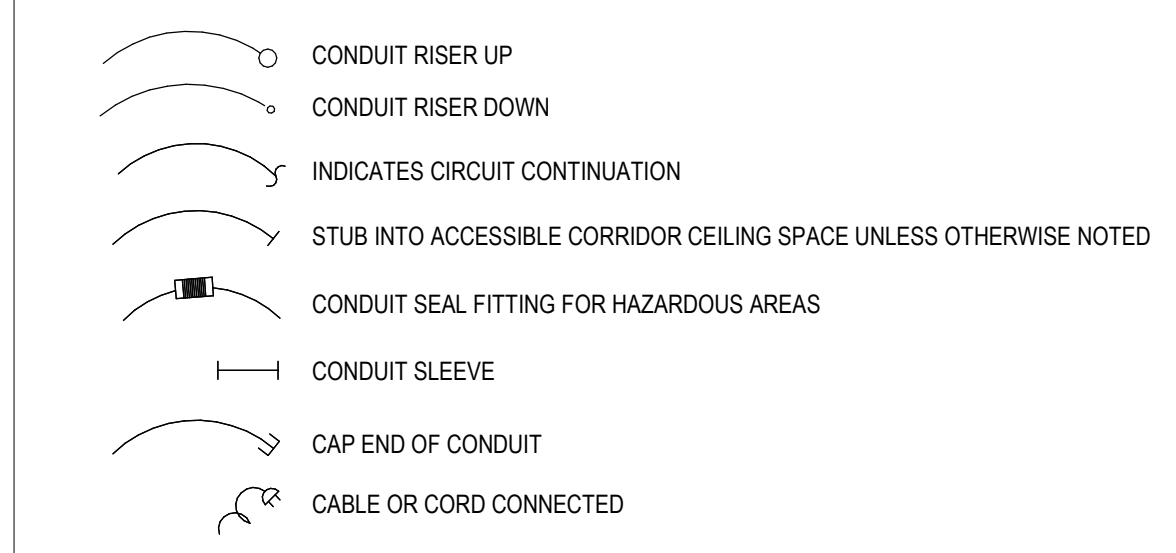

LIGHTING

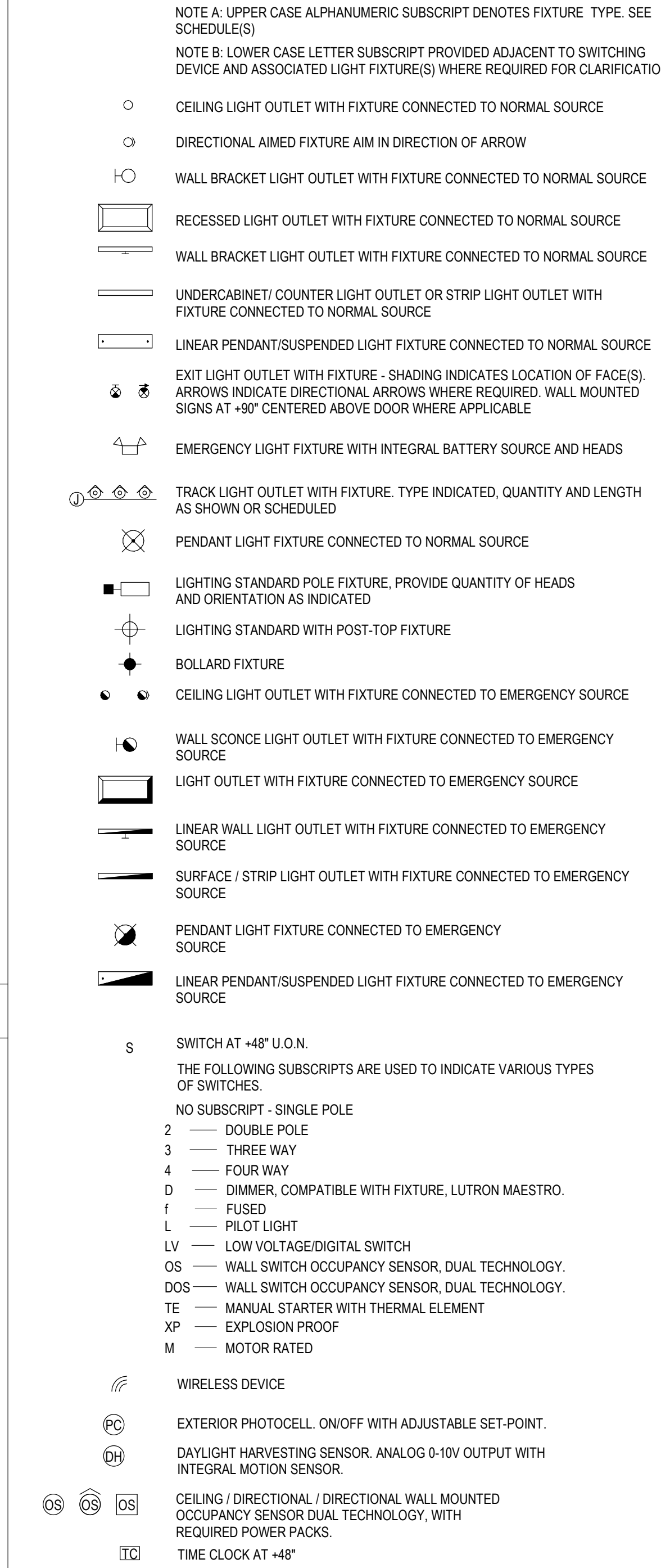

POWER AND DIAGRAMS

NOTE:
A. OUTLETS IN FINISHED OR SHELL SPACES SHALL BE MOUNTED AT -18" UON.
B. OUTLETS IN GARAGE, MECHANICAL, AND ELECTRICAL SPACES SHALL BE MOUNTED AT 48" UON.
C. OUTLETS SHALL BE TAMPER PROOF, WHERE REQUIRED PER CODE.
D. OUTLETS SHALL HAVE AFCI PROTECTION, WHERE REQUIRED PER CODE.
E. OUTLETS SHALL HAVE GFCI PROTECTION, WHERE REQUIRED PER CODE.

THE FOLLOWING SUBSCRIPTS ARE USED TO INDICATE DIFFERENT TYPES OF RECEPTACLES

WP — WEATHERPROOF, EXTRA DUTY, WITH STEEL IN-USE COVER.
CL — CLOCK MOUNTED AT -84", REGRESSED SINGLE RECEPTACLE, WITH CLOCK HANGER.
H — HORIZONTAL MOUNTING
U — DUAL USB INCLUDED WITH RECEPTACLE TYPE SHOWN.

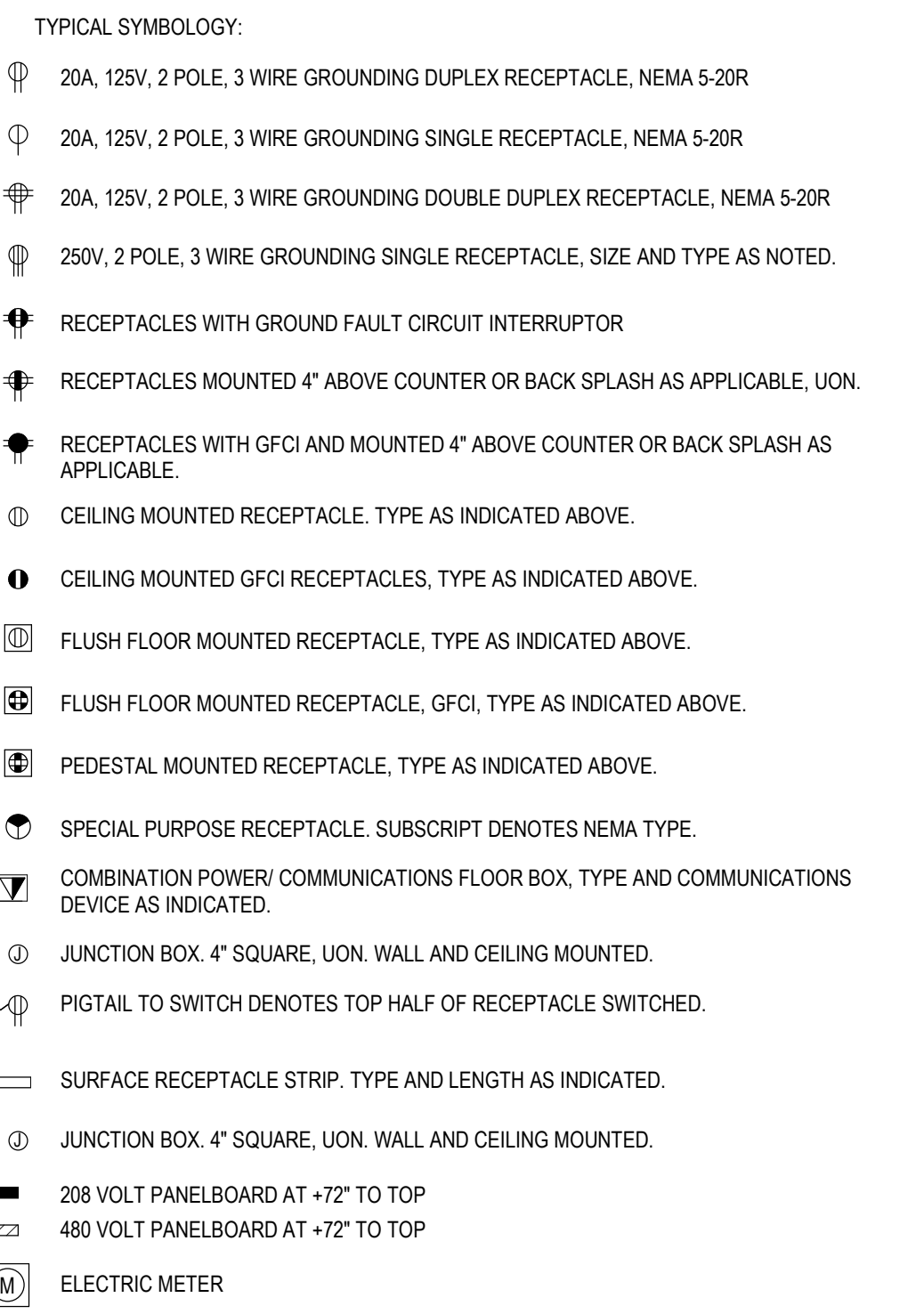

FIRE DETECTION AND ALARM

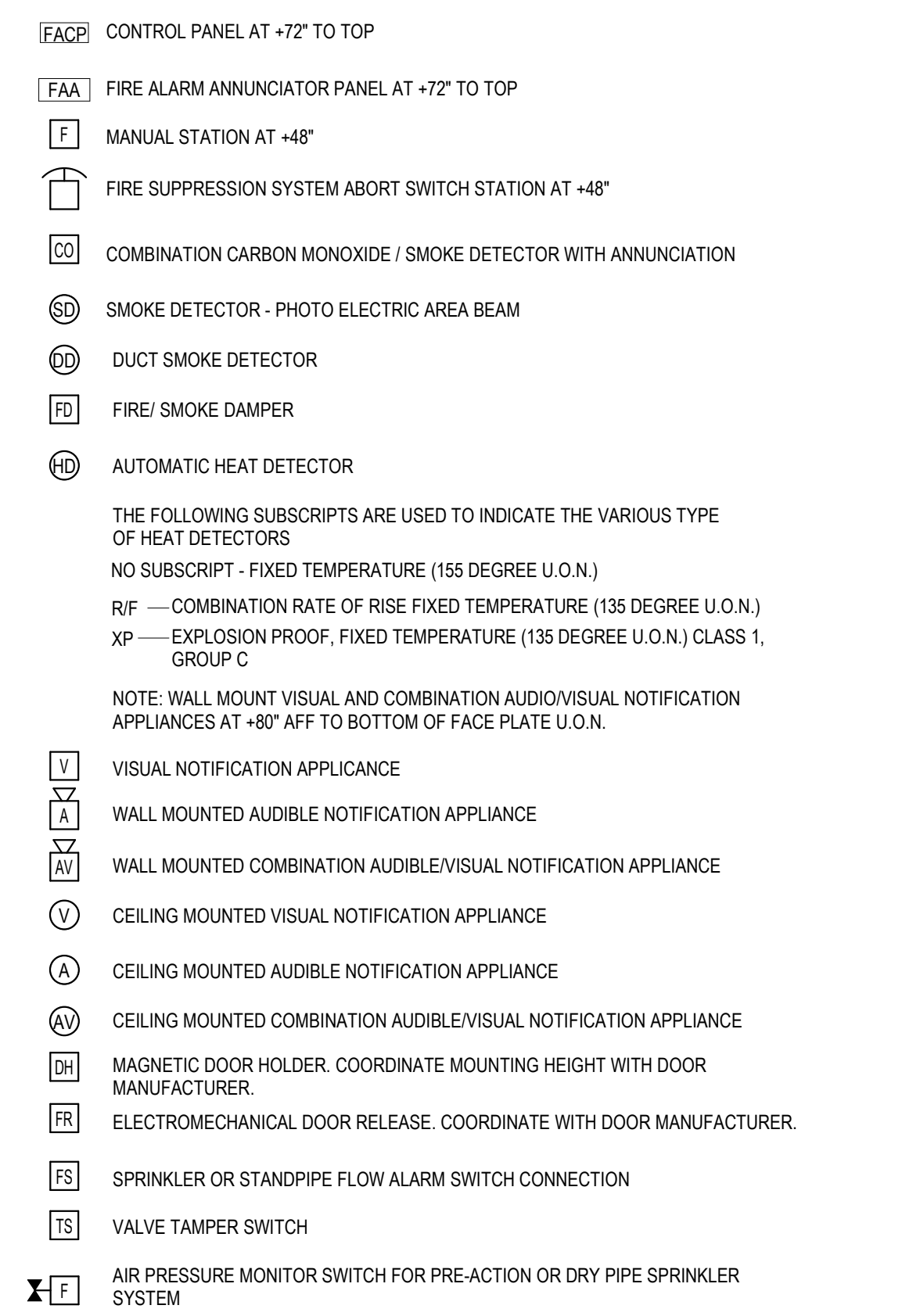

TELECOMMUNICATION

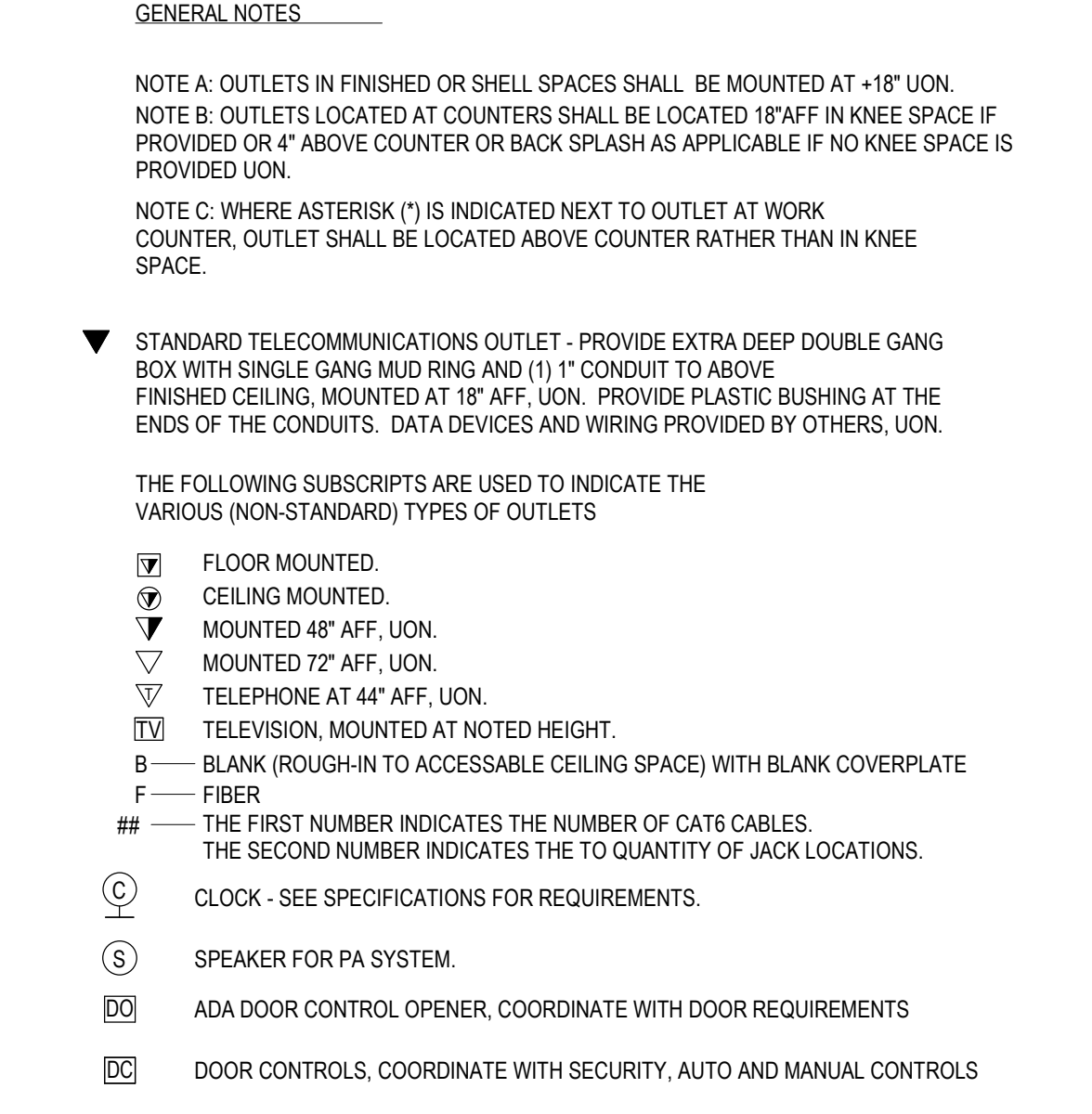

SECURITY

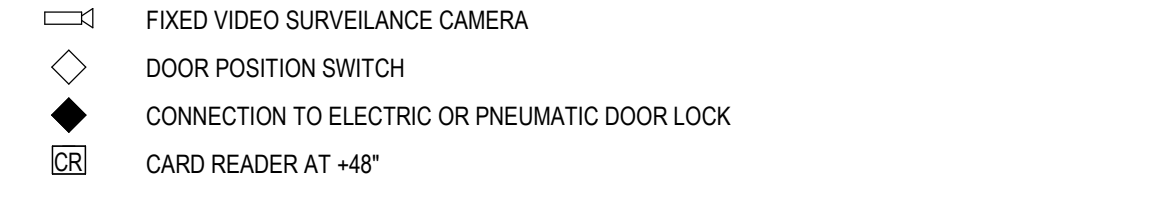

NOTE:
SYMBOLS SHOWN ARE FOR REFERENCE ONLY AND DO NOT CONSTITUTE A CHECK LIST OF DEVICES REQUIRED BY THE CONTRACT

GENERAL

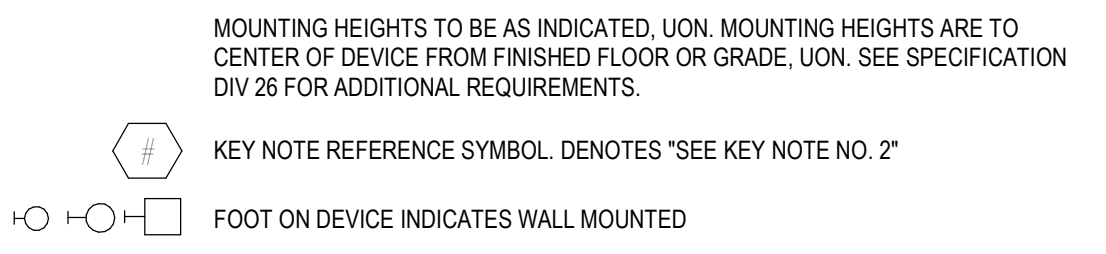

Disclaimer: The drawings found within this set are Substantially Complete, but are marked "Not for Construction," as it will be necessary for each site-specific development to employ architects and/or engineers to evaluate local conditions, make necessary adjustments required for local permitting. Some items are indicated as blanks for local verification.

- GENERAL NOTES:**
- ALL WORK SHALL BE INSTALLED IN ACCORDANCE WITH THE LATEST ACCEPTED EDITION OF THE NATIONAL ELECTRICAL CODE, NEC, AND ALL STATE AND LOCAL CODES.
 - COORDINATE THE INSTALLATION OF ALL ELECTRICAL EQUIPMENT AND CONNECTIONS WITH ARCHITECTURAL, STRUCTURAL, MECHANICAL AND EQUIPMENT DRAWINGS.
 - ELECTRICAL CONTRACTOR SHALL PROVIDE AND INSTALL ALL POWER, CONDUITS, AND OTHER COMPONENTS AS SHOWN ON THE EQUIPMENT PROVIDER DRAWINGS FOR INSTALLATION OF SYSTEM.
 - "BACK TO BACK" OR THROUGH THE WALL BOXES SHALL NOT BE USED.
 - INSTALL HANDLE LOCK-ON, ON ALL CIRCUIT BREAKERS CONTROLLING NIGHT LIGHT, EMERGENCY LIGHT AND EXIT LIGHT CIRCUITS.
 - ALL RECEPTACLES SHALL BE COMMERCIAL SPECIFICATION GRADE.
 - PROVIDE TAMPER RESISTANT RECEPTACLES WHERE REQUIRED BY APPLICABLE CODES.
 - RECEPTACLES INDICATED AS GROUND FAULT CIRCUIT INTERRUPTER TYPE SHALL BE MOUNTED IN AN ACCESSIBLE LOCATION, PER CODE OR PROVIDED WITH A GFCI BREAKER.
 - ALL CONDUCTORS SHALL BE COPPER. ALUMINUM WIRES SHALL NOT BE USED.
 - MINIMUM CONDUIT SIZE SHALL BE 1/2" FOR POWER FEEDS AND 1" FOR COMMUNICATION FEEDS.
 - FINAL CONNECTION TO ITEMS SUBJECT TO VIBRATION SHALL BE MADE WITH LIQUID/TIGHT FLEXIBLE METALLIC CONDUIT.
 - 120/240VAC CIRCUIT WIRING FOR ANY ROOM OR AREA MAY BE GROUPED INTO RACEWAYS UNLESS SEPARATE RACEWAYS ARE REQUIRED BY THE NEC. COMPLY WITH NEC REQUIREMENTS FOR CONDUCTOR DERATING.
 - PROVIDE EQUIPMENT GROUNDING CONDUCTORS FOR ALL POWER AND LIGHTING CIRCUITS.
 - ALL LIGHTING AND POWER CONDUCTORS SHALL BE 12 AWG MINIMUM. ALL CONTROL CONDUCTORS SHALL BE 14 AWG MINIMUM OR AS SPECIFIED BY MANUFACTURER.
 - DEDICATED NEUTRAL SHALL BE PROVIDED FOR ALL CIRCUITS. SHARED NEUTRALS ARE NOT ALLOWED.
 - BASIS OF DESIGN IS FOR A COMPLETE ELECTRICAL SYSTEM, INSTALLED PER CODE REQUIREMENTS.
 - PROVIDE AN UNSWITCHED HOT TO ALL EMERGENCY BATTERY PACKS, LIGHTING INVERTERS AND EMERGENCY LIGHTING UNITS AHEAD OF AN LIGHTING CONTROLS FROM THE BRANCH CIRCUIT SERVING LIGHTING IN THE SURROUNDING AREA.

Do not scale.
Use figured dimensions only.
MML Review Set
22 AUG 2022

NOT FOR CONSTRUCTION

THE LINDEN
Michigan Municipal League

Job Number:
2022xx
Title:
ELECTRICAL COVER SHEET

E0.1

Disclaimer: The drawings found within this set are Substantially Complete, but are marked "Not for Construction," as it will be necessary for each site-specific development to employ architects and/or engineers to evaluate local conditions, make necessary adjustments required for local permitting. Some items are indicated as blanks for local verification.

Do not scale.
Use figured
dimensions only.
MML Review Set
22 AUG 2022

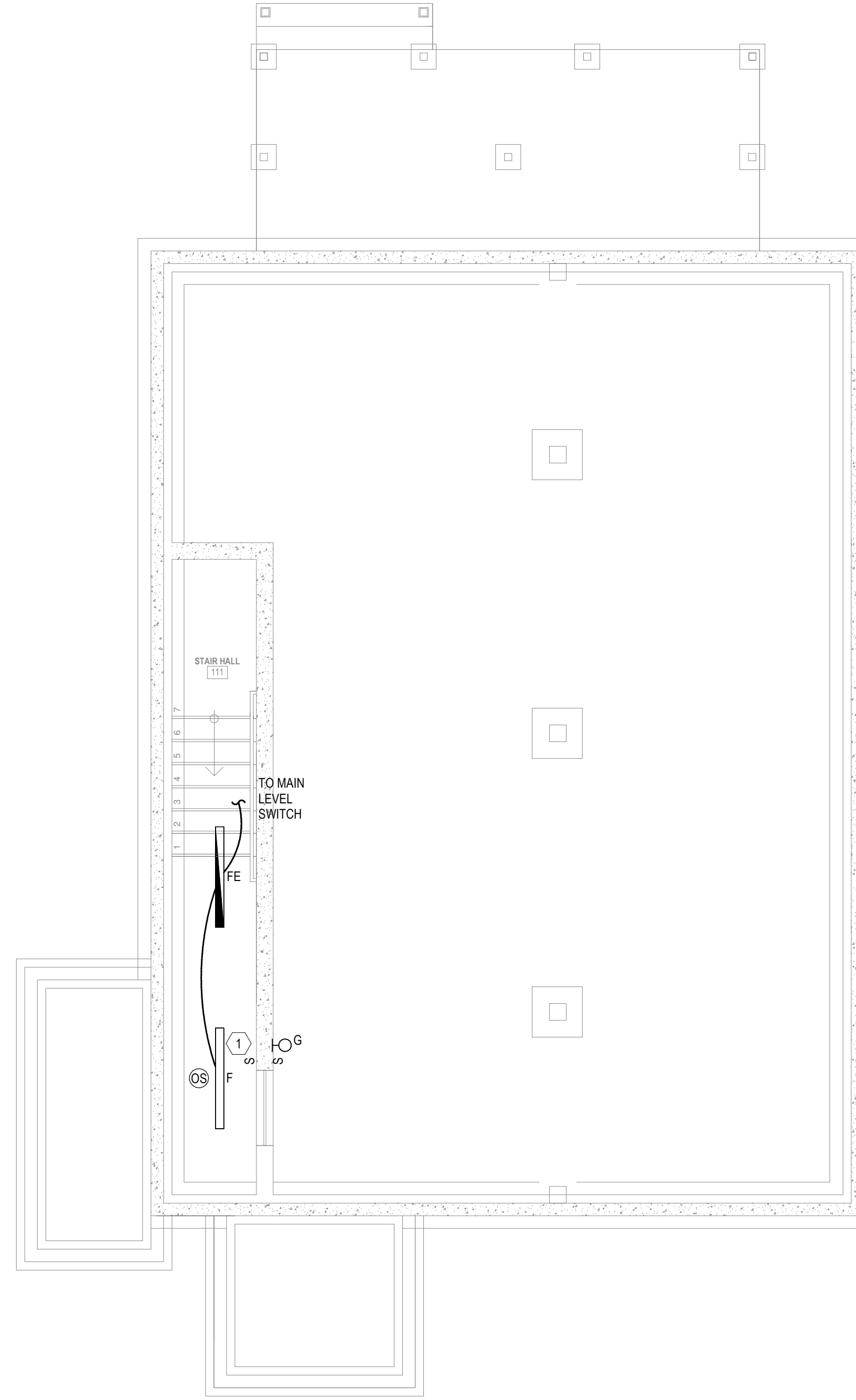

KEYNOTES:
1 SEE DETAIL 3/E5.1 FOR WIRING DIAGRAM.

1 FOUNDATION PLAN - ELECTRICAL
E1.1 SCALE = 1/4" = 1'-0"

NOT FOR CONSTRUCTION

THE LINDEN
Michigan Municipal League

Job Number:
2022xx
Title:
FOUNDATION
PLAN -
ELECTRICAL

E1.1

Disclaimer: The drawings found within this set are Substantially Complete, but are marked "Not for Construction," as it will be necessary for each site-specific development to employ architects and/or engineers to evaluate local conditions, make necessary adjustments required for local permitting. Some items are indicated as blanks for local verification.

Do not scale.
Use figured
dimensions only.
MML Review Set
22 AUG 2022

KEYNOTES:
1 SEE DETAIL 3/E5.1 FOR WIRING DIAGRAM.

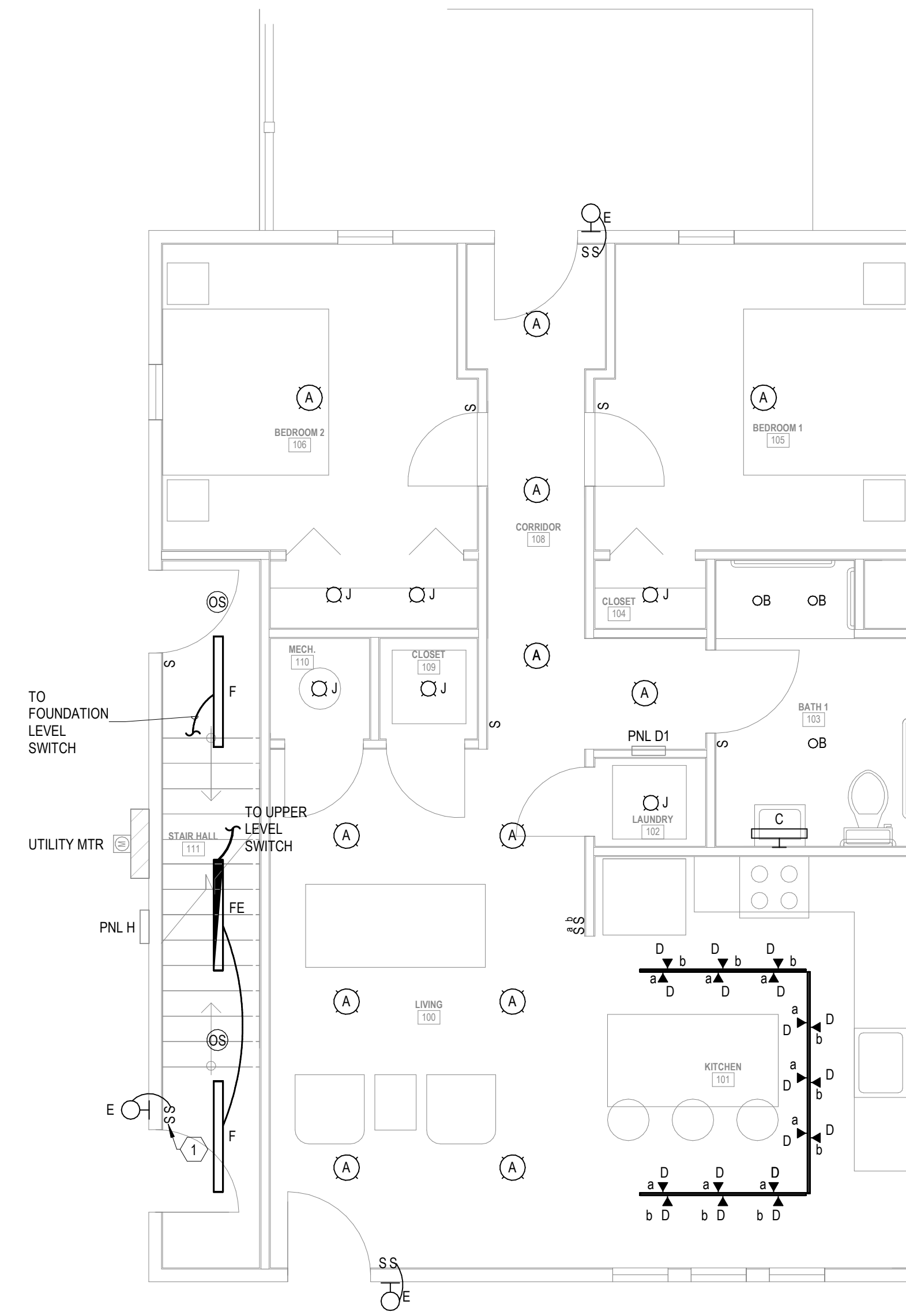

1 MAIN PLAN - LIGHTING
E1.2 SCALE = 1/4" = 1'-0"

NOT FOR CONSTRUCTION

THE LINDEN
Michigan Municipal League

Job Number:
2022xx
Title:
MAIN LEVEL
PLAN - LIGHTING

E1.2

Disclaimer: The drawings found within this set are Substantially Complete, but are marked "Not for Construction," as it will be necessary for each site-specific development to employ architects and/or engineers to evaluate local conditions, make necessary adjustments required for local permitting. Some items are indicated as blanks for local verification.

Do not scale.
Use figured
dimensions only.
MML Review Set
22 AUG 2022

KEYNOTES:
1 SEE DETAIL 3/ES.1 FOR WIRING DIAGRAM.

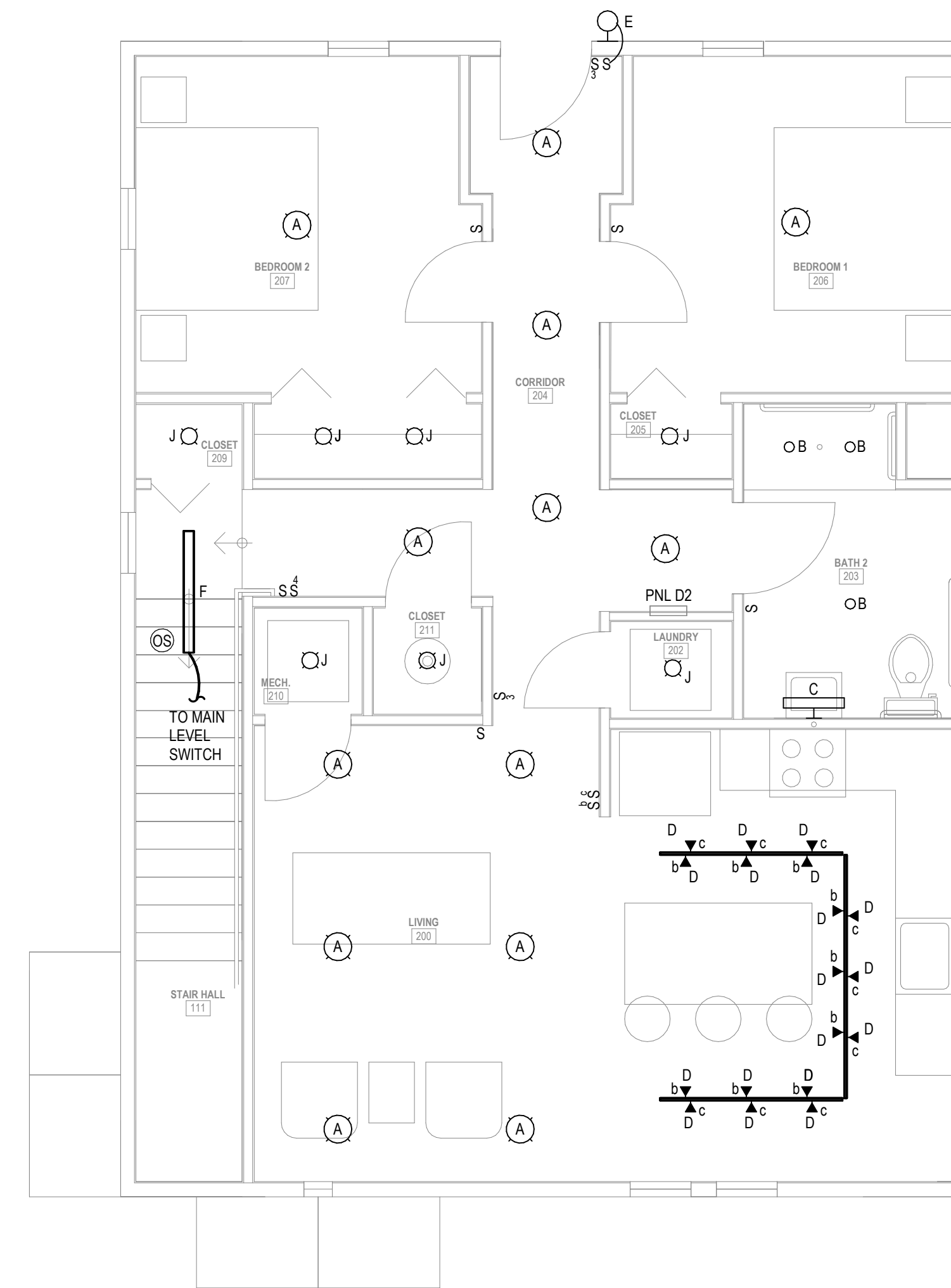

1 UPPER LEVEL PLAN - LIGHTING
E1.3 SCALE = 1/4" = 1'-0"

NOT FOR CONSTRUCTION

THE LINDEN
Michigan Municipal League

Job Number:
2022xx
Title:
UPPER LEVEL
PLAN - LIGHTING

E1.3

Disclaimer: The drawings found within this set are Substantially Complete, but are marked "Not for Construction," as it will be necessary for each site-specific development to employ architects and/or engineers to evaluate local conditions, make necessary adjustments required for local permitting. Some items are indicated as blanks for local verification.

Do not scale.
Use figured
dimensions only.
MML Review Set
22 AUG 2022

- # KEYNOTES:
- 1 BATH EXHAUST FAN SWITCH.
 - 2 EMPTY CONDUIT WITH PULL ROPE CAPPED ABOVE GRADE 5'-0" FROM BUILDING.

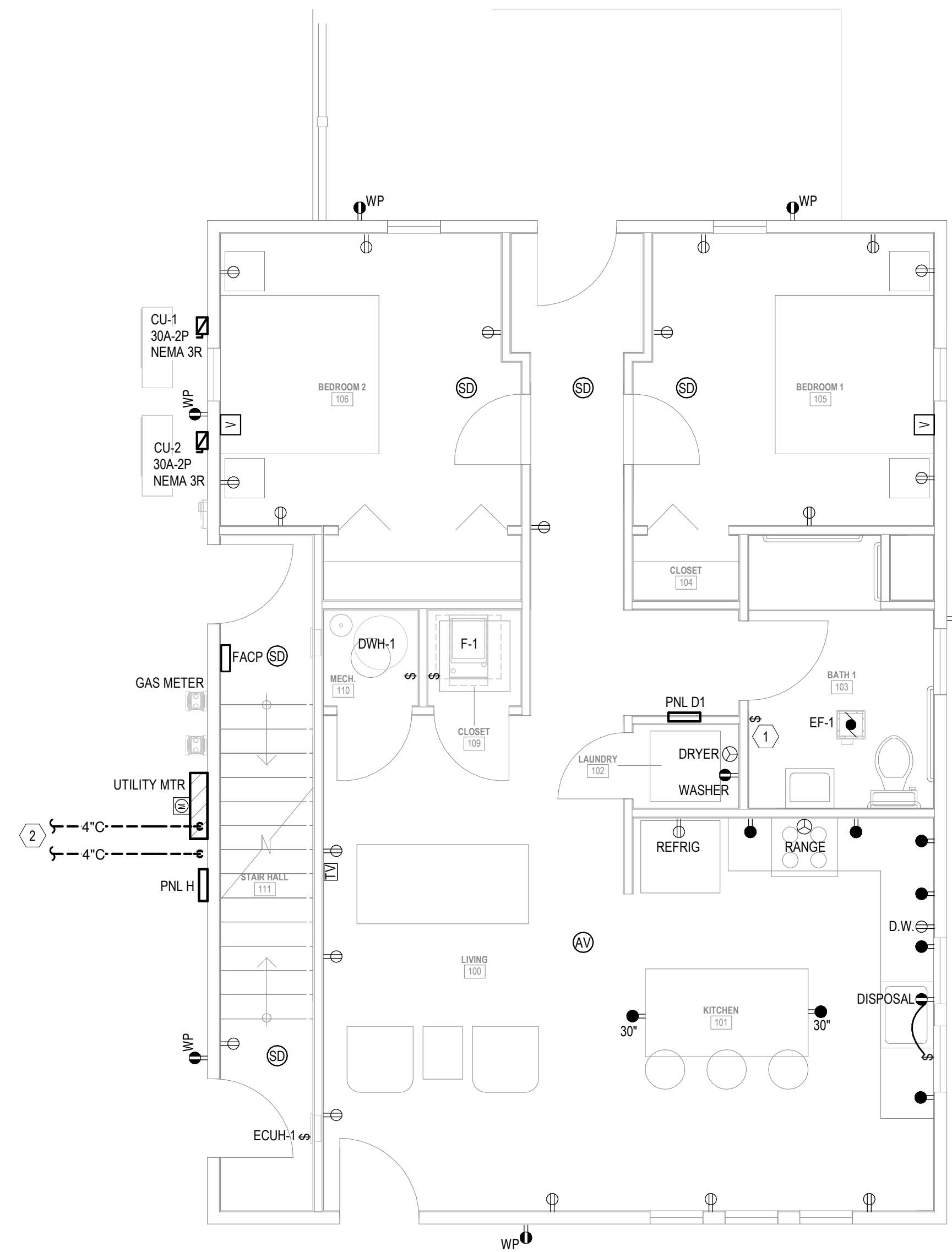

1 UPPER LEVEL PLAN - ELECTRICAL
E2.1 SCALE = 1/4" = 1'-0"

NOT FOR CONSTRUCTION

THE LINDEN
Michigan Municipal League

Job Number:
2022xx
Title:
MAIN LEVEL
PLAN - POWER
AND SYSTEMS

E2.1

Disclaimer: The drawings found within this set are Substantially Complete, but are marked "Not for Construction," as it will be necessary for each site-specific development to employ architects and/or engineers to evaluate local conditions, make necessary adjustments required for local permitting. Some items are indicated as blanks for local verification.

Do not scale.
Use figured
dimensions only.
MML Review Set
22 AUG 2022

NOT FOR CONSTRUCTION

THE LINDEN
Michigan Municipal League

Job Number:
2022xx
Title:
UPPER LEVEL
PLAN - POWER
AND SYSTEMS

E2.2

KEYNOTES:
1 BATH EXHAUST FAN SWITCH.

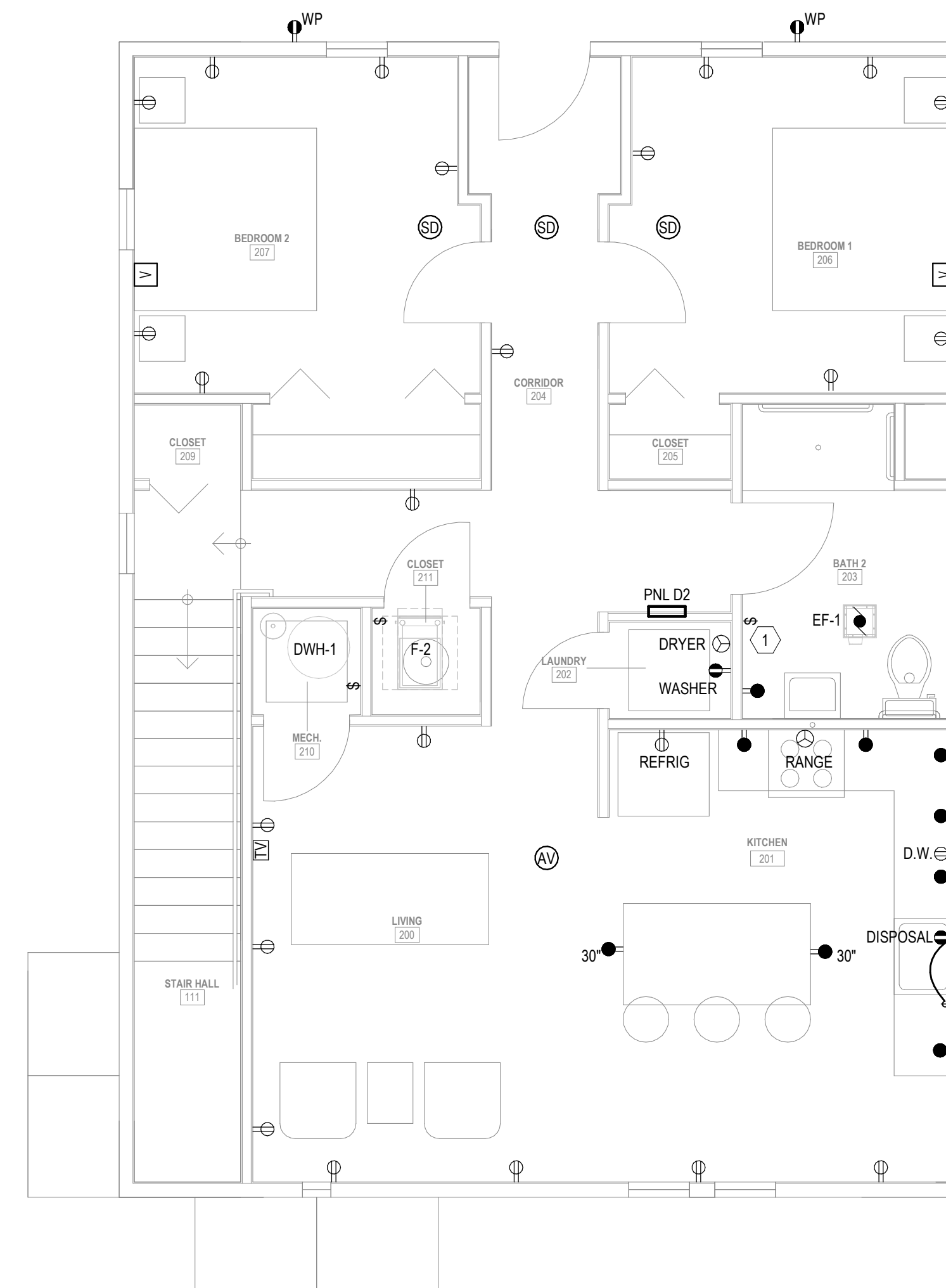

1 UPPER LEVEL PLAN - POWER AND SYSTEMS
E2.2 SCALE = 1/4" = 1'-0"

Disclaimer: The drawings found within this set are Substantially Complete, but are marked "Not for Construction," as it will be necessary for each site-specific development to employ architects and/or engineers to evaluate local conditions, make necessary adjustments required for local permitting. Some items are indicated as blanks for local verification.

Do not scale.
Use figured
dimensions only.
MML Review Set
22 AUG 2022

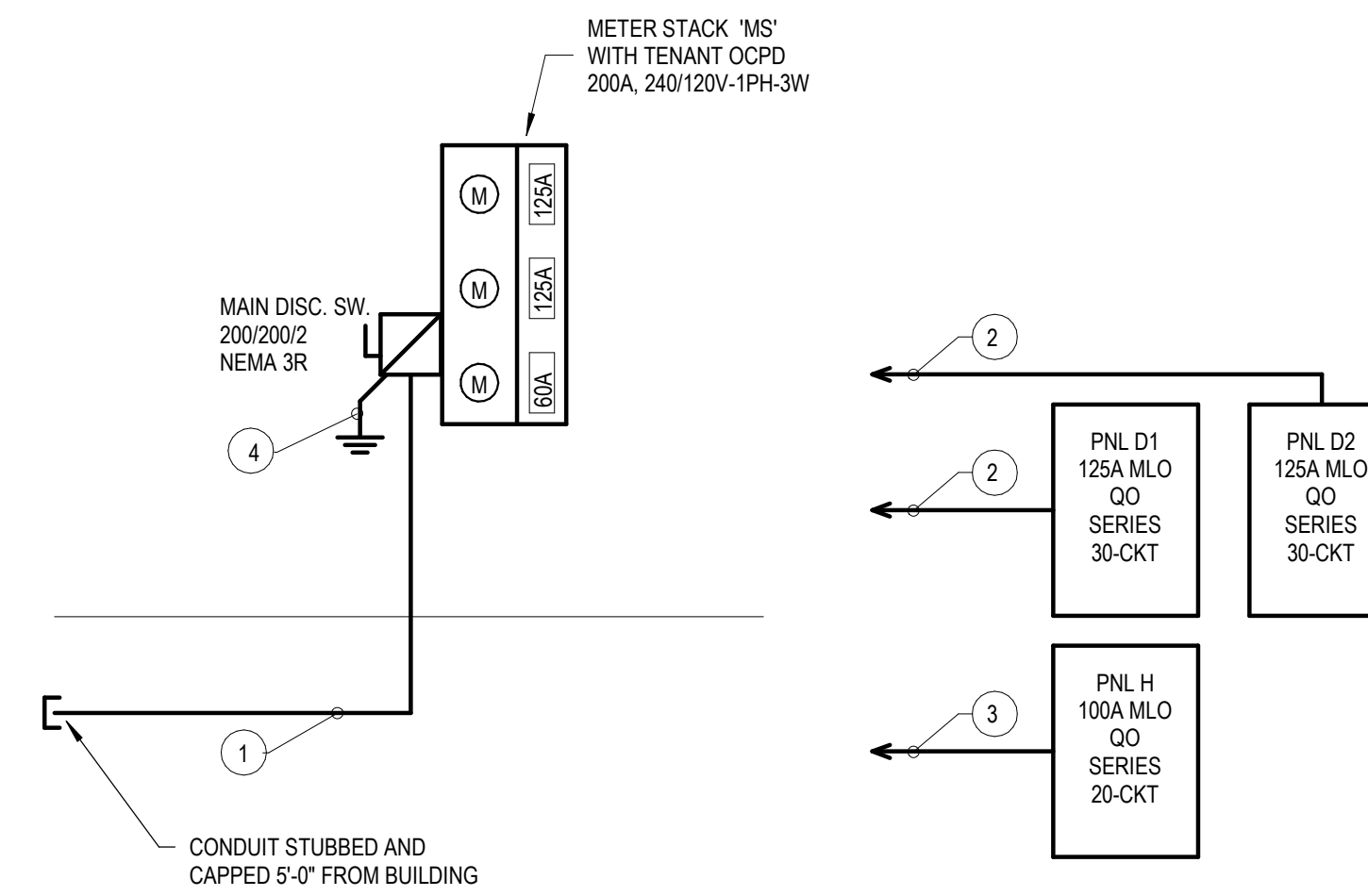

1 **120/240V ELECTRICAL RISER DIAGRAM**
ES.1 NOT TO SCALE

CABLE/CONDUIT SCHEDULE

- 1 EMPTY 4" CONDUIT WITH PULL ROPE
- 2 3#1, #6 GND, 1 1/2" C
- 3 3#1, #8 GND, 1 1/2" C
- 4 #6 AWG GND, GEC

NOTE:
I_{sc} (L-L): 13495 AMPS AT METERING EQUIPMENT. AVAILABLE FAULT CURRENT CALCULATIONS ARE BASED ON AN ASSUMPTION OF 50KVA TRANSFORMER WITH AN INFINITE PRIMARY AND A 2.5% IMPEDENCE. CONTRACTOR TO CONFIRM WITH THE UTILITY COMPANY THE AVAILABLE FAULT CURRENT AND ADJUST AIC RATINGS FOR ALL ELECTRICAL EQUIPMENT PRIOR TO ORDERING.

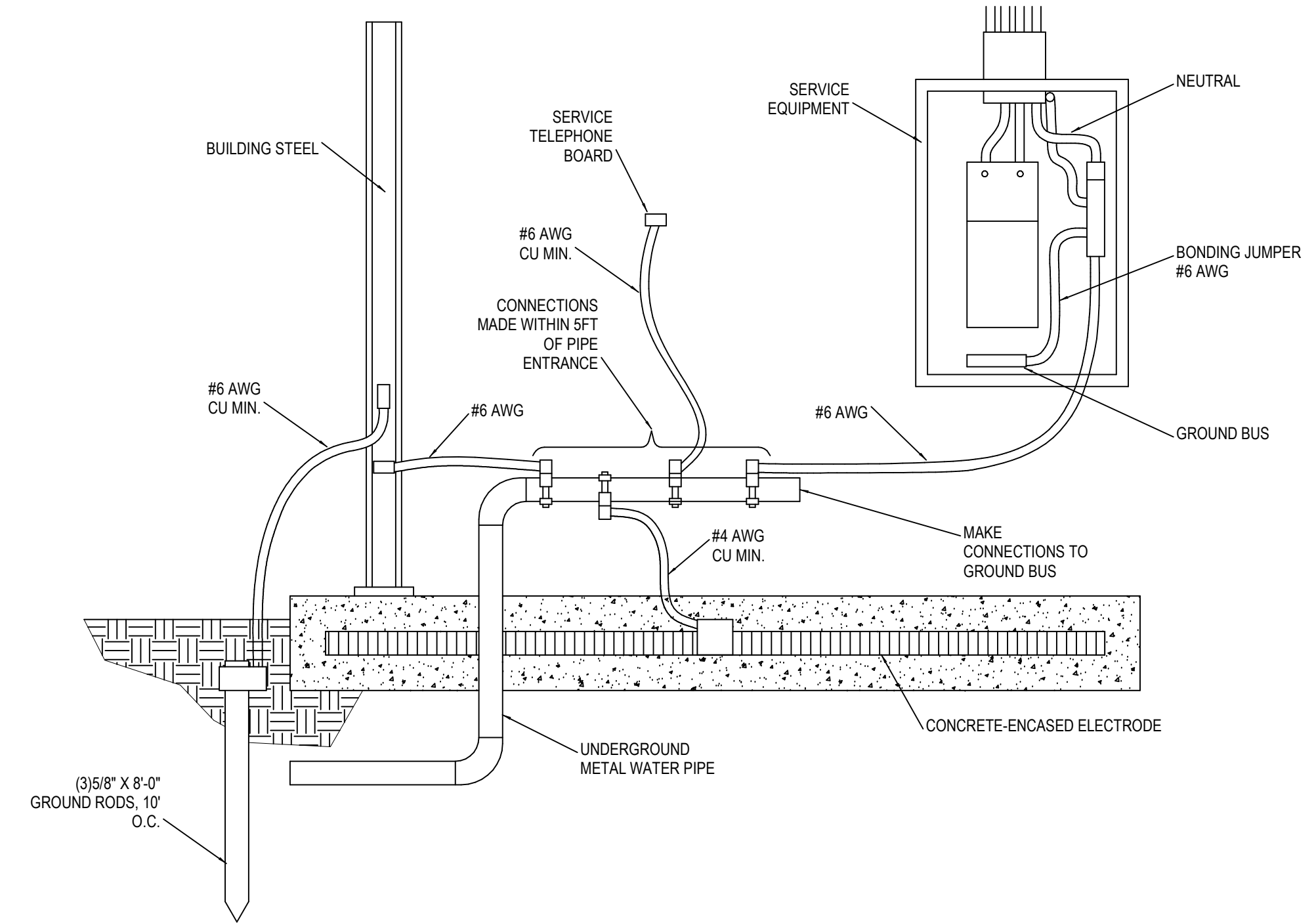

2 **GROUNDING AND BONDING DETAIL**
ES.1 NOT TO SCALE

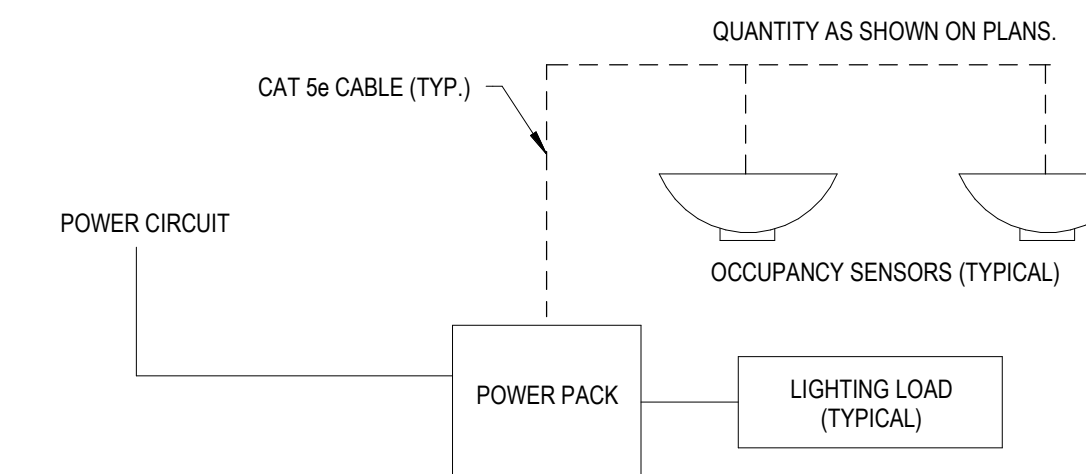

BASIS OF DESIGN:
1. ACUITY HLIGHT.

APPROVED ALTERNATES:
1. EATON
2. LEVITON
3. HUBBELL NX

SEQUENCE OF OPERATION:
1. ALL CONTROLS TO BE COMPLIANT WITH ASHRAE 90.1, 2013 WITHOUT MICHIGAN EXCEPTIONS FOR LEED COMPLIANCE.
2. MANUAL "ON", LOCAL ON/OFF OVERRIDE, AUTO "OFF".
3. SEE PLANS FOR SPECIFIC QUANTITY AND LOCATION OF SWITCH TYPES.

3 **LIGHTING CONTROL DIAGRAM**
ES.1 NOT TO SCALE

NOT FOR CONSTRUCTION

THE LINDEN
Michigan Municipal League

Job Number:
2022xx
Title:
ELECTRICAL
DETAILS

E5.1

Disclaimer: The drawings found within this set are Substantially Complete, but are marked "Not for Construction," as it will be necessary for each site-specific development to employ architects and/or engineers to evaluate local conditions, make necessary adjustments required for local permitting. Some items are indicated as blanks for local verification.

Do not scale.
Use figured
dimensions only.
MML Review Set
22 AUG 2022

NOT FOR CONSTRUCTION

THE LINDEN
Michigan Municipal League

Job Number:
2022xx
Title:
ELECTRICAL
SCHEDULES

E7.1

LIGHT FIXTURE SCHEDULE

ID	MANUFACTURER	MODEL NO.	VOLTAGE	REQUIRED LAMPS			DESCRIPTION	NOTES
				QTY	WATT	TYPE		
A	JUNO	J5F-11IN-13LM-35K-90CRI-MVOLTZT-WH	MVOLT	1	15 W	LED, 3500K, 1300LM, 90CRI	LED SURFACE MOUNT DOWNLIGHT	
B	JUNO	IC1LED-G4-14LM-35K-90CRI-MVOLTZT1	MVOLT	1	17 W	LED, 3500K, 1400LM, 90CRI	4" DOWNLIGHT, WHITE FLANGE, 1% DIMMING	
C	LITHONIA	FMV7SL-24IN-MVOLT-30K-90CRI-BN-IM	MVOLT	1	10 W	LED, 3000K, 1300LM, 90CRI, L70@50,000	4" LINEAR WALL BRACKET	
D	JUNO	R60SL-35K-90CRI-PDIM-WFL-WH / TU	120V	1	10 W	LED, 3500K, 850LM	TRACK HEAD AND TRACK SECTION	
E	SIGNATURE HARDWARE	SKU: 941513	120V	1	10 W	LED, 3000K, 1200LM	OUTDOOR ENTRANCE WALL SCONCE	
F	LITHONIA	WL4-40L-EZ1-LP835-MSD7	MVOLT	1	28 W	LED, 3500K, 4000LM	1X4 SURFACE LED	
FE	LITHONIA	WL4-40L-EZ1-LP835-MSD7-EL14L	MVOLT	1	28 W	LED, 3500K, 4000LM	1X4 SURFACE LED WITH 14W EMERG BATTERY	
G	LITHONIA	OLVTWM	MVOLT	1	15 W	LED, 4000K, 600LM	GENERAL PURPOSE LED VAPORTITE WALL MOUNTED	
H	LITHONIA	OLVTGM	MVOLT	1	15 W	LED, 4000K, 600LM	GENERAL PURPOSE LED VAPORTITE	
J	CLOUDY BAY	LSF4108	120V	1	10 W	LED, 3500K, 1300LM, 90CRI	MOTION SENSOR CEILING LIGHT	

Panel: H

Location: EXTERIOR
Supply From: UTILITY
Mounting: SURFACE
Enclosure: TYPE 3R
Series: LOAD CENTER

Volts: 120/240 Single
Phases: 1
Wires: 3

A.I.C. Rating: 10kAIC
Mains Type: MLO
Mains Rating: 100 A
Bus Rating: 100 A
Neutral Buss: Yes
Ground Buss: Yes

Sub-Feed Lugs: No

Notes:

CKT	Circuit Description	Trip	Poles	A		B		Circuit Description	CKT
				0.00	1.00	0.60	0.00		
1	LTG STAIR HALL FOUNDATION	20	1	0.00	1.00			ECUH-1 STAIR HALL-3 111-3	2
3	FIRE ALARM PANELSTAIR HALL-1...	20	1			0.60	0.00	SPARE	4
5	SPARE	20	1	0.00	0.00			SPARE	6
7	SPARE	20	1			0.00	0.00	SPARE	8
9	SPARE	20	1	0.00	0.00			SPARE	10
11	SPARE	20	1			0.00	0.00	SPARE	12
13	SPARE	20	1	0.00	0.00			SPARE	14
15	SPARE	20	1			0.00	0.00	SPARE	16
17	SPARE	20	1	0.00	0.00			SPARE	18
19	SPARE	20	1			0.00	0.00	SPARE	20
				Total Load:	1 kW	1 kW			
				Total Amps:	8 A	5 A			

Load Classification	Connected Load	Demand Factor	Estimated Demand	Panel Totals
Motor	1000 VA	125.00%	1250 VA	
Other	600 VA	100.00%	600 VA	
				Total Load: 1.60 kW
				Demand Load: 1.85 kW
				Connected Amps: 7 A
				Demand Amps: 8 A

Notes:

Panel: D1

Location: UNIT D1
Mounting: RECESSED
Enclosure: TYPE 1
Series: LOAD CENTER

Volts: 120/240 Single
Phases: 1
Wires: 3

A.I.C. Rating: 10kAIC
Mains Type: MLO
Mains Rating: 125 A
Bus Rating: 125 A
Neutral Buss: Yes
Ground Buss: Yes

Notes:

* PROVIDE GFCI CIRCUIT BREAKER.
PROVIDE AFCI CIRCUIT BREAKER AS REQUIRED BY THE NEC.

CKT	Circuit Description	Trip	Poles	A		B		Circuit Description	CKT
				0.00	1.00	0.60	0.00		
1	LTG HALL, BDRM, BATH	20	1	1	20	LTG LIVING, KITCHEN	2
3	RECEPT BATH	20	1	1	20	RECEPT LIVING	4
5	RECEPT BEDROOM 1	20	1	1	20	DISPOSAL KITCHEN	6
7	RECEPT BEDROOM 2	20	1	1	20	* D.W. KITCHEN	8
9	SPARE	20	1	1	20	RECEPT REFRIG KITCHEN	10
11	FURNACE F-1 CLOSET	20	1	1	20	* MICRO KITCHEN	12
13	DWH1.1 MECH	20	1	1	20	RECEPT KITCHEN	14
15	SPARE	20	1	1	20	RECEPT KITCHEN	16
17	SPARE	20	1	1	20	RECEPT KITCHEN	18
19	SPARE	20	1	1	20	SPARE	20
21	WASHER LAUNDRY	20	1	1	20	SPARE	22
23	DRYER LAUNDRY	30	2	1	20	SPARE	24
25	--	--	--	1	20	SPARE	26
27	CU-2 EXTERIOR	20	2	2	50	RANGE KITCHEN	28
29	--	--	--	--	--	--	30

Notes:

Panel: D2

Location: UNIT D2
Mounting: RECESSED
Enclosure: TYPE 1
Series: LOAD CENTER

Volts: 120/240 Single
Phases: 1
Wires: 3

A.I.C. Rating: 10kAIC
Mains Type: MLO
Mains Rating: 125 A
Bus Rating: 125 A
Neutral Buss: Yes
Ground Buss: Yes

Notes:

* PROVIDE GFCI CIRCUIT BREAKER.
PROVIDE AFCI CIRCUIT BREAKER AS REQUIRED BY THE NEC.

CKT	Circuit Description	Trip	Poles	A		B		Circuit Description	CKT
				0.00	1.00	0.60	0.00		
1	LTG HALL, BDRM, BATH	20	1	1	20	LTG HALL, BDRM, BATH	2
3	RECEPT BATH	20	1	1	20	RECEPT LIVING	4
5	RECEPT BEDROOM 1	20	1	1	20	DISPOSAL KITCHEN	6
7	RECEPT BEDROOM 2	20	1	1	20	* D.W. KITCHEN	8
9	SPARE	20	1	1	20	RECEPT REFRIGERATOR	10
11	F-2 CLOSET	20	1	1	20	* MICRO KITCHEN	12
13	DWH1.2 MECH	20	1	1	20	RECEPT KITCHEN	14
15	SPARE	20	1	1	20	RECEPT KITCHEN	16
17	SPARE	20	1	1	20	RECEPT KITCHEN	18
19	SPARE	20	1	1	20	SPARE	20
21	WASHER LAUNDRY	20	1	1	20	SPARE	22
23	DRYER LAUNDRY	30	2	1	20	SPARE	24
25	--	--	--	1	20	SPARE	26
27	CU-2 EXTERIOR	20	2	2	50	RANGE KITCHEN	28
29	--	--	--	--	--	--	30

Notes:

PLUMBING ABBREVIATIONS

ATC	ARCHITECTURAL TRADES CONTRACTOR
AFF	ABOVE FINISHED FLOOR
BFS	BELOW FLOOR SLAB
BTU	BRITISH THERMAL UNIT
CA	COMPRESSED AIR
CD	CONDENSATE DRAIN
CO	CLEAN OUT
COTG	CLEAN OUT TO GRADE
CF	COLD WATER
DW	DRINKING FOUNTAIN
DIAMØ	DIAMETER
DWH	DOMESTIC WATER HEATER
ETC	ELECTRICAL TRADES CONTRACTOR
EWC	ELECTRIC WATER COOLER
FCO	FLOOR CLEAN OUT
FD	FLOOR DRAIN
G	GAS (NATURAL)
G (2-PSI)	NATURAL GAS (2-PSI)
G (5-PSI)	NATURAL GAS (5-PSI)
GPM	GALLONS PER MINUTE
HB	HOSE BIBB
HP	HORSE POWER
HVAC	HEATING/VENTILATION/AIR CONDITIONING
HWR	HOT WATER RETURN
HW	HOT WATER
INV OR I.E.	INVERT ELEVATION
LAV	LAVATORY
MTC	MECHANICAL TRADES CONTRACTOR
MBH	BTU PER HOUR (THOUSAND)
MS	MOP SINK
ORC	OVER-FLOW RAIN CONDUCTOR
ORD	OVER-FLOW ROOF DRAIN
PVC	POLYVINYL CHLORIDE
RC	RAIN CONDUCTOR
RD	ROOF DRAIN
SAN	SANITARY
SH	SHOWER
SK	SINK
SS	SOIL STACK
ST	STORM
TYP	TYPICAL
UR	URINAL
VAC	VACUUM
VB	VACUUM BREAKER
V	VENT
VS	VENT STACK
VTR	VENT THRU ROOF
W	WASTE
WC	WATER CLOSET
WCO	WALL CLEANOUT
WH	WALL HYDRANT
WS	WASTE STACK
X	EXISTING

NOTE:
ALL ABBREVIATIONS AND SYMBOLS SHOWN ON THIS SHEET MAY NOT BE USED ON THIS PROJECT.

PLUMBING SYMBOLS

	KEY NOTE
	CONNECTION POINT, NEW TO EXISTING
	DEMOLITION END POINT
	PIPE TURNED UP
	PIPE TURNED DOWN
	PIPE OUT OF TOP
	PIPE OUT OF BOTTOM
	COLD WATER
	HOT WATER
	HOT WATER RETURN
	VENT PIPE
	LOW PRESSURE GAS
	HIGH PRESSURE GAS
	MEDIUM PRESSURE GAS
	SANITARY
	SANITARY BELOW FLOOR SLAB
	RAIN CONDUCTOR
	RAIN CONDUCTOR BELOW FLOOR SLAB
	OVERFLOW RAIN CONDUCTOR
	FIRE PROTECTION
	FLOW DIRECTION
	GATE VALVE
	GAS COCK
	CHECK VALVE
	BALL VALVE
	CIRCUIT BALANCE VALVE
	BUTTERFLY VALVE
	WATER METER
	GAS METER
	STRAINER
	HOSE BIBB/WALL HYDRANT
	GAS REGULATOR
	RELIEF VALVE
	SHOWER HEAD

GENERAL PLUMBING NOTES

- A. PIPING LAYOUT IS SCHEMATIC. EXACT LOCATION OF PIPING AND EQUIPMENT SHALL BE COORDINATED WITH BUILDING STRUCTURE, EQUIPMENT FURNISHED, ARCHITECTURAL DRAWINGS AND ALL OTHER TRADES PRIOR TO INSTALLATION. ANY CONTRACTOR INSTALLING WORK WITHOUT PRIOR COORDINATION SHALL RELOCATE HIS WORK AT HIS EXPENSE TO ALLOW PROPER INSTALLATION OF ANY AND ALL TRADES' WORK.
- B. ALL WORK SHALL COMPLY WITH THE MICHIGAN PLUMBING CODE AND ALL APPLICABLE LOCAL CODES.
- C. ALL INVERTS, STATED OR NOT, NEW OR EXISTING, SHALL BE COORDINATED IN THE FIELD, VERIFY EXISTING INVERTS PRIOR TO STARTING WORK.
- D. UNLESS OTHERWISE NOTED, ALL PIPING SHALL BE CONCEALED WHEREVER POSSIBLE. PROVIDE CHROME ESCUTCHEON AT EACH PENETRATION OF A FINISHED SURFACE.
- E. PLUMBING UTILITY PIPING SHALL NOT BE RUN ABOVE ELECTRICAL GEAR OR IN THE SERVICE SPACE REQUIRED BY THE NATIONAL ELECTRICAL CODE.
- F. PROVIDE SHOCK ABSORBER IN THE DOMESTIC COLD AND HOT WATER PIPING. SHOCK ABSORBERS TO BE LOCATED IN AN ACCESSIBLE LOCATION.
- G. ALL WALL AND SLAB PENETRATIONS OF MASONRY OR CONCRETE CONSTRUCTION SHALL BE SLEEVED.
- H. PROVIDE ISOLATION SEPARATORS FOR COPPER PIPING RUNNING THROUGH METAL STUDS.
- I. ALL FLOOR DRAINS ARE TO HAVE AN APPROVED TRAP SEAL DEVICE.
- J. ALL FIXTURES SHALL HAVE SHUTOFF STOP VALVES IN AN ACCESSIBLE LOCATION. PIPING BEYOND THE STOP VALVES AND EXPOSED IN OCCUPIED SPACES SHALL BE CHROME-PLATED. ANY NOTED SHUTOFF VALVES ARE IN ADDITION TO THIS REQUIREMENT.
- K. PROVIDE FIRE STOPPING AT ALL PENETRATIONS OF FIRE RATED ENCLOSURES.

Disclaimer: The drawings found within this set are Substantially Complete, but are marked "Not for Construction," as it will be necessary for each site-specific development to employ architects and/or engineers to evaluate local conditions, make necessary adjustments required for local permitting. Some items are indicated as blanks for local verification.

PIPE INSULATION SCHEDULE								
FLUID OPERATING TEMP RANGE, °F	INSULATION CONDUCTIVITY		NOMINAL PIPE OR TUBE SIZE, INCHES				NOTE	
	CONDUCTIVITY RANGE BTU-IN/HR-FT ² -°F	MEAN TEMP RATING, °F	<1	1 TO <1.5	1.5 TO <4	4 TO <8		>8
			INSULATION THICKNESS, INCHES					
105°+ (DOM. HW)	0.22 - 0.28	100°	0.5 ^a	0.5 ^a	1.0 ^a	1.0 ^a	1.0 ^a	2
DOM. HW W/ HWR	0.27	100°	1.0 ^c	1.0 ^c	1.0 ^{ac}	1.0 ^{ac}	1.0 ^{ac}	2
40° TO 60°	0.21 - 0.27	75°	1.5 ^{bd}	1.5 ^{bd}	1.5 ^{bd}	1.5 ^{bd}	1.5 ^{bd}	1
> 40°	0.20 - 0.26	50°	1.5 ^{bd}	1.5 ^{bd}	1.5 ^{bd}	1.5 ^{bd}	1.5 ^{bd}	1
DOMESTIC CW	0.21 - 0.27	75°	1.0	1.0	1.0	1.0	1.0	1

NOTE: THE VALUES LISTED IN THE SCHEDULE ARE BASED ON THE MICHIGAN UNIFORM ENERGY CODE (BASED ON ASHRAE 90.1-2013), 2015 INTERNATIONAL ENERGY CONSERVATION CODE (IECC) (AS REFERENCED BY 2015 MICHIGAN MECHANICAL CODE), & 2018 MICHIGAN PLUMBING CODE (MPC). THE MORE STRINGENT REQUIREMENTS ARE USED AS LISTED BELOW. VERIFY THE VALUES COMPLY WITH THE CODES IN EFFECT AT THE TIME OF CONSTRUCTION AND ADJUST ACCORDINGLY.

CODE REFERENCES:

- a. FROM ASHRAE 90.1, TABLE 6.8.3-1 "MINIMUM PIPING INSULATION THICKNESS" FOR "HEATING AND HOT WATER SYSTEMS (STEAM, STEAM CONDENSATE, HOT WATER HEATING AND DOMESTIC WATER SYSTEMS)"
- b. FROM ASHRAE 90.1, TABLE 6.8.3-2 "MINIMUM PIPING INSULATION THICKNESS" FOR "COOLING SYSTEMS (CHILLED WATER, BRINE, AND REFRIGERANT)."
- c. FROM IECC, SECTION C404 "SERVICE WATER HEATING (MANDATORY)" PARAGRAPH C404.4 "INSULATION OF PIPING."
- d. FROM IECC, TABLE C403.2.10 "MINIMUM PIPE INSULATION THICKNESS."

NOTES:

1. PROVIDE WITH VAPOR BARRIER. HANGERS/SUPPORTS SHALL BE INSTALLED OUTSIDE OF INSULATION.
2. THE FOLLOWING DOMESTIC/SERVICE HOT WATER PIPING SHALL BE INSULATED AS INDICATED:
 - a. RECIRCULATING SYSTEM PIPING, INCL THE SUPPLY AND RETURN PIPING OF A CIRCULATING TANK TYPE WATER HEATER.
 - b. THE FIRST 8 FT. OF OUTLET PIPING FOR A CONSTANT TEMPERATURE NONRECIRCULATING STORAGE SYSTEM.
 - c. THE INLET PIPE BETWEEN THE STORAGE TANK AND A HEAT TRAP IN A NONRECIRCULATING STORAGE SYSTEM.
 - d. PIPES THAT ARE EXTERNALLY HEATED (SUCH AS HEAT TRACE OR IMPEDANCE HEATING).

Do not scale. Use figured dimensions only.

Review Set
14 JUL 2022
MML Review Set
22 AUG 2022

NOT FOR CONSTRUCTION

THE LINDEN
Michigan Municipal League

Job Number:
2022xx
Title:
PLUMBING COVER SHEET

P0.1

Disclaimer: The drawings found within this set are Substantially Complete, but are marked "Not for Construction," as it will be necessary for each site-specific development to employ architects and/or engineers to evaluate local conditions, make necessary adjustments required for local permitting. Some items are indicated as blanks for local verification.

Do not scale.
Use figured
dimensions only.
MML Review Set
22 AUG 2022

NOT FOR CONSTRUCTION

THE LINDEN
Michigan Municipal League

Job Number:
2022xx
Title:
PLUMBING
FLOOR PLANS

P1.1

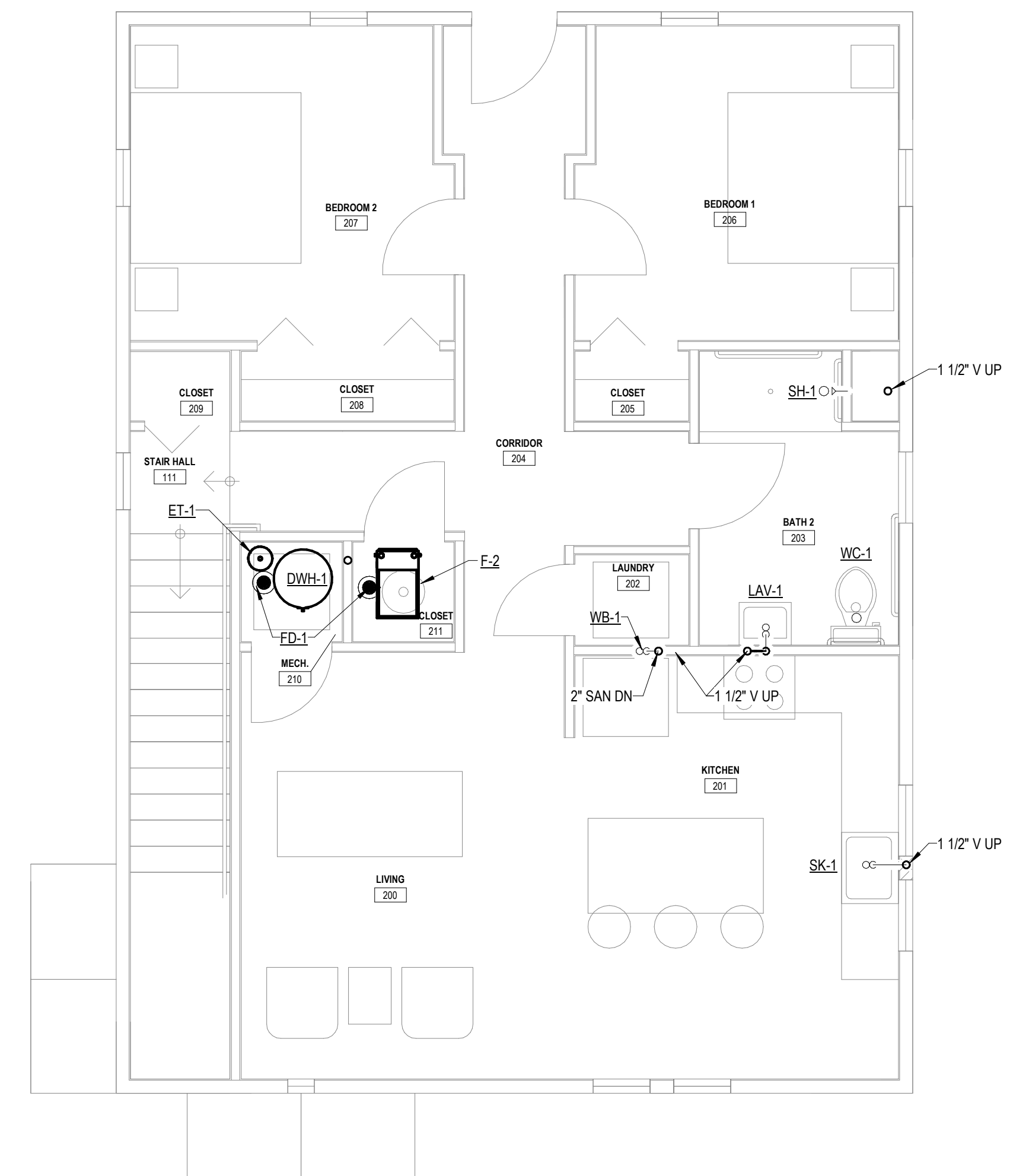

3 UPPER LEVEL FLOOR PLAN - PLUMBING
P1.1 SCALE = 1/4" = 1'-0"

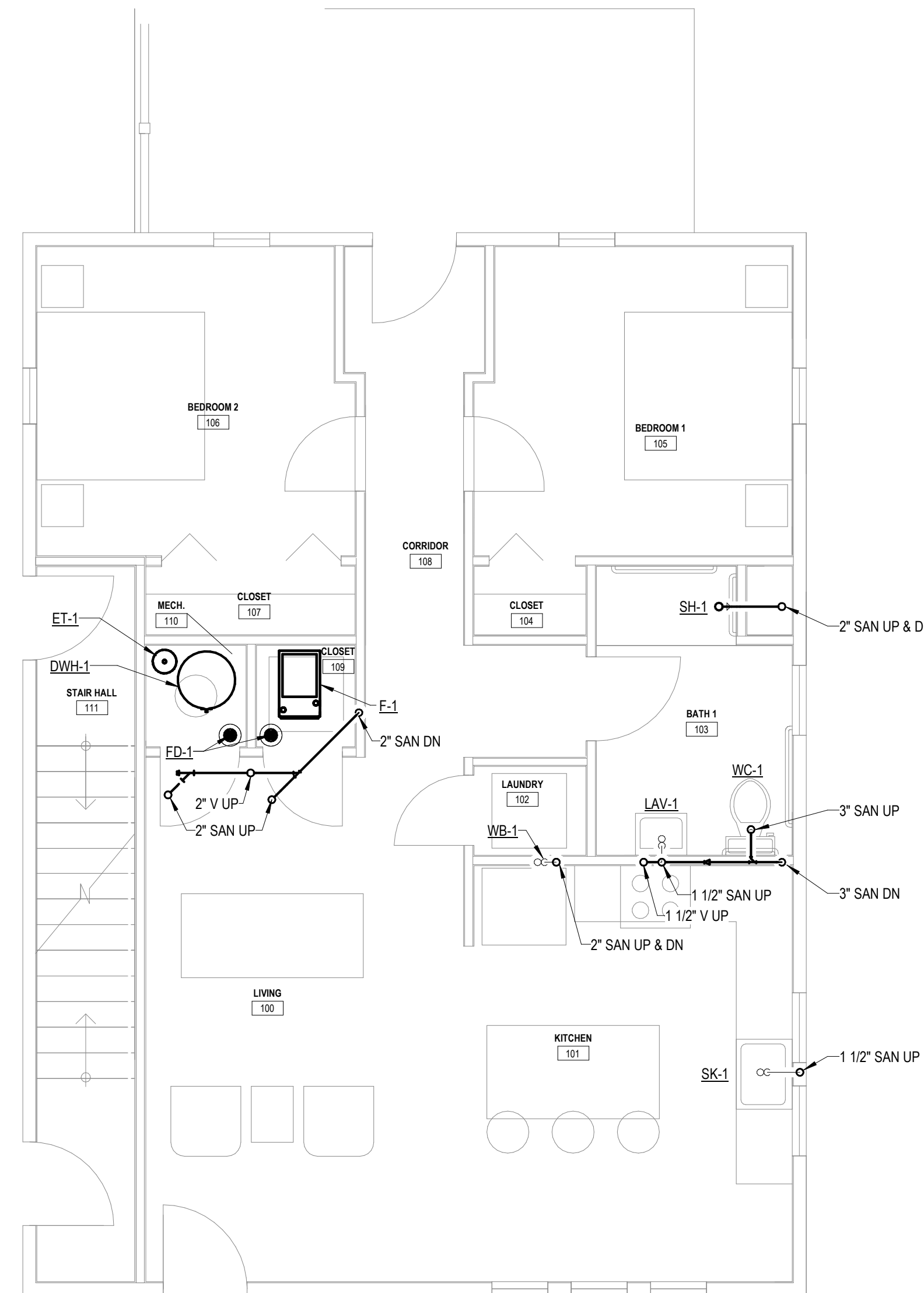

2 MAIN FLOOR PLAN - PLUMBING
P1.1 SCALE = 1/4" = 1'-0"

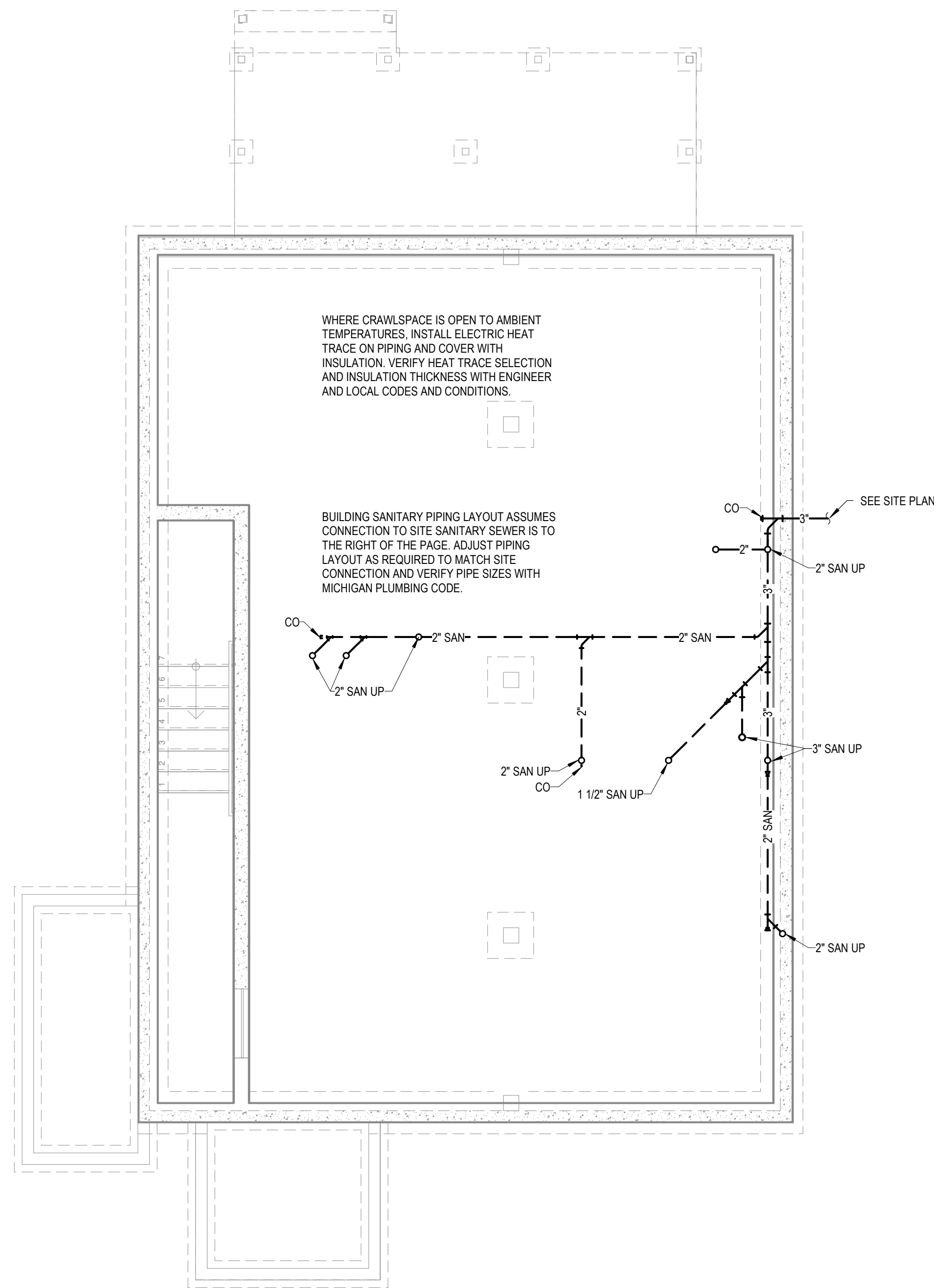

1 FOUNDATION FLOOR PLAN - PLUMBING
P1.1 SCALE = 1/4" = 1'-0"

Disclaimer: The drawings found within this set are Substantially Complete, but are marked "Not for Construction," as it will be necessary for each site-specific development to employ architects and/or engineers to evaluate local conditions, make necessary adjustments required for local permitting. Some items are indicated as blanks for local verification.

Do not scale.
Use figured
dimensions only.
MML Review Set
22 AUG 2022

NOT FOR CONSTRUCTION

DOMESTIC WATER HEATER SCHEDULE

TAG	BASIS OF DESIGN		DESCRIPTION	STORAGE CAPACITY (GALLONS)	RECOVERY GPH	RISE OF RECOVERY DEG. F.	EWT DEG. F.	LWT DEG. F.	ELECTRICAL DATA		COMMENTS
	MANUFACTURER	MODEL							DWH KW	DWH VOLTAGE	
DWH-1	Bradford White	RE240LN6	Residential Lowboy Electric Water Heater	37	19	100	50	120	4.5	120V / 1Ø	

EXPANSION TANK SCHEDULE

TAG	DESIGN BASIS		TANK VOLUME (GALLONS)	MAXIMUM ACCEPTANCE VOLUME (GALLONS)	SYSTEM CONNECTION SIZE	ASME Rated	COMMENTS
	MANUFACTURER	MODEL					
ET-1	Amtrol	ST-5	2.0 gal	0.90	3/4"	No	

PLUMBING FIXTURE CONNECTION SCHEDULE

TAG	FIXTURE TYPE	PIPE CONNECTION DATA				ELECTRICAL DATA		COMMENTS
		COLD WATER	HOT WATER	VENT	SANITARY	FLA	VOLTAGE	
FD-1	FLOOR DRAIN	-	-	1-1/2"	2"	-	-	
LAV-1	LAVATORY	1/2"	1/2"	1-1/4"	1-1/2"	-	-	
SH-1	SHOWER	1/2"	1/2"	1-1/2"	2"	-	-	
SK-1	KITCHEN SINK	1/2"	1/2"	1-1/4"	1-1/2"	-	-	
WB-1	WASHER BOX	1/2"	1/2"	1-1/2"	2"	-	-	
WC-1	TANK TYPE WATER CLOSET	1/2"	1/2"	1-1/2"	3"	-	-	

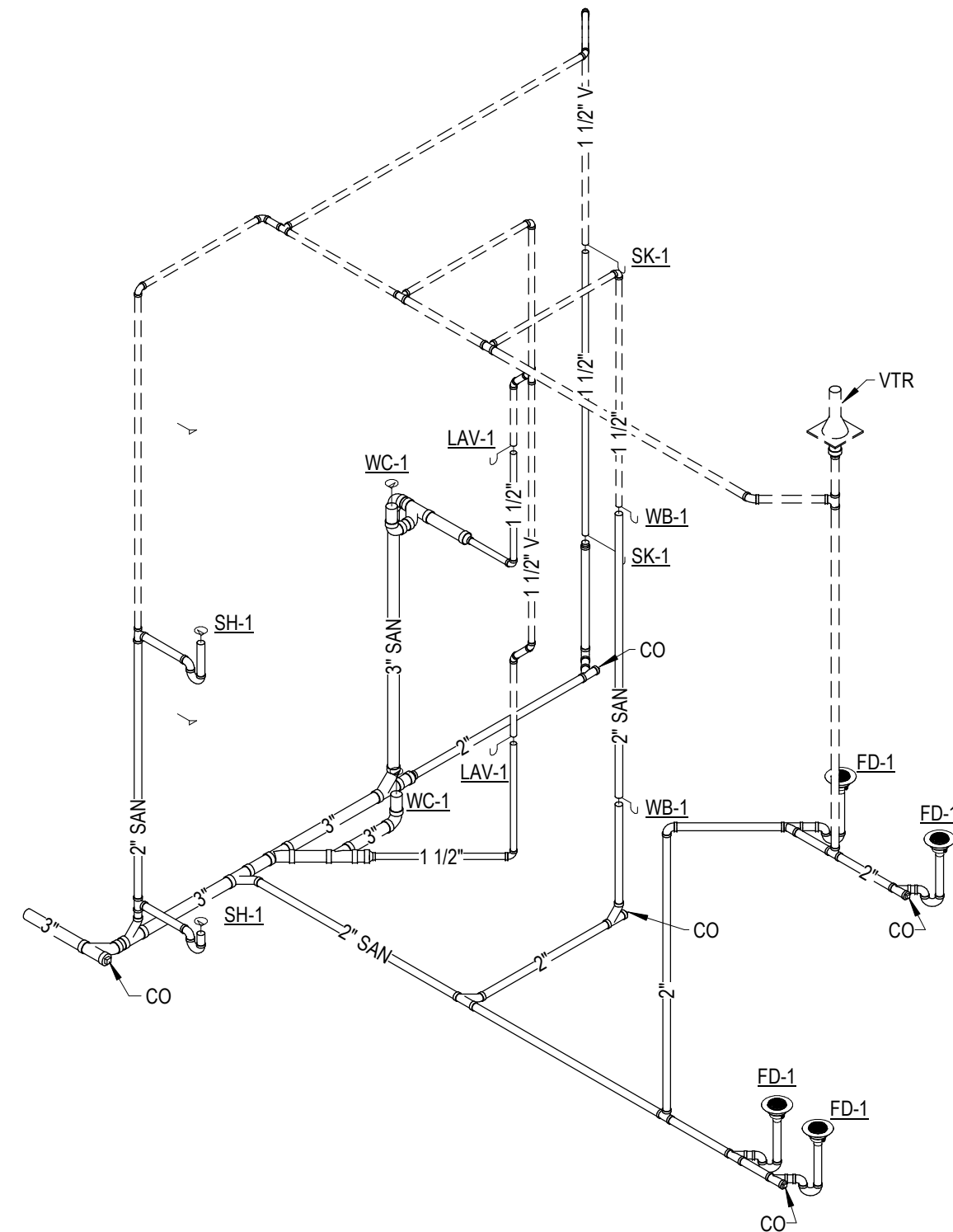

1 **SANITARY ISOMETRIC**
P6.1 NOT TO SCALE

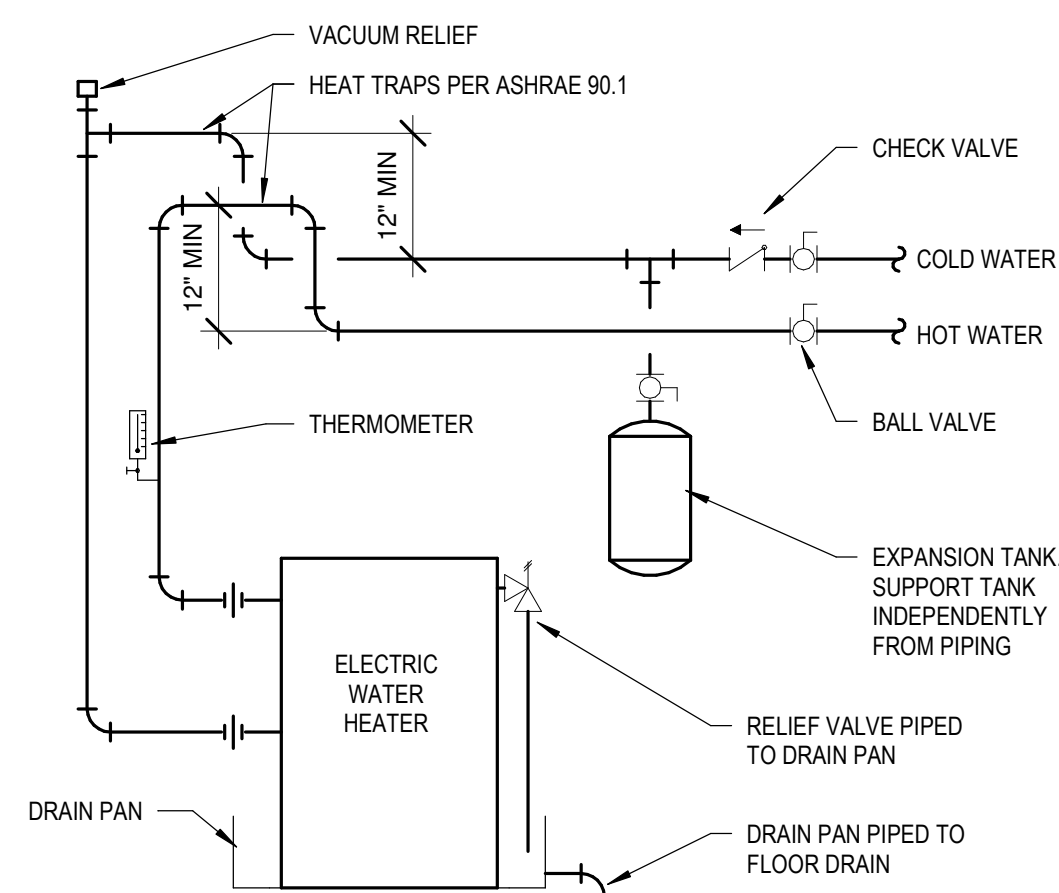

2 **DOMESTIC WATER HEATER PIPING SCHEMATIC**
P6.1 NOT TO SCALE

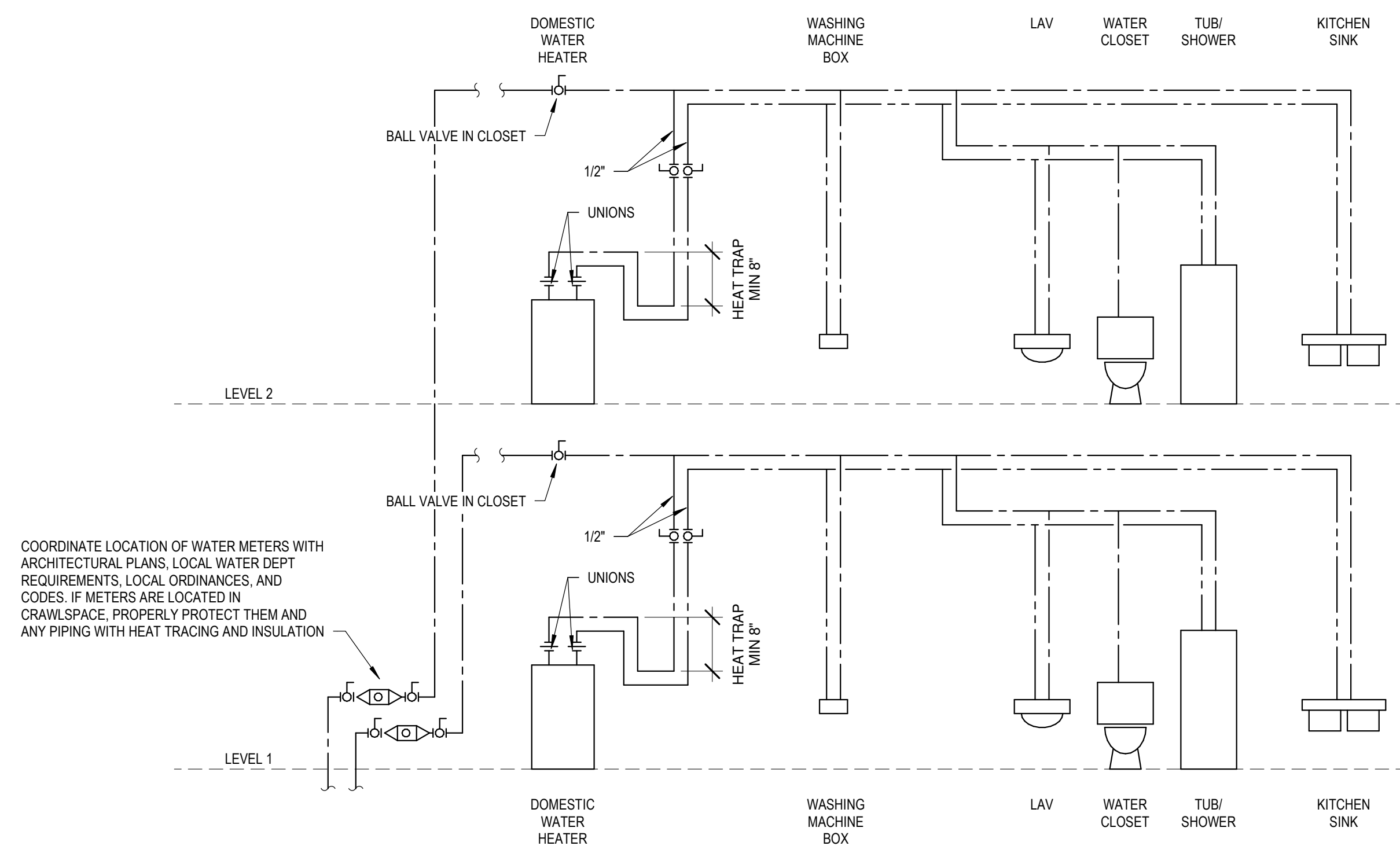

3 **DOMESTIC WATER PIPING SCHEMATIC**
P6.1 NOT TO SCALE

THE LINDEN
Michigan Municipal League

Job Number:
2022xx
Title:
PLUMBING
SCHEDULES &
DETAILS

P6.1

HVAC ABBREVIATIONS

ATC	ARCHITECTURAL TRADES CONTRACTOR
AC	AIR CONDITIONING(ER)
AFF	ABOVE FINISHED FLOOR
AHU	AIR HANDLING UNIT
AMB	AMBIENT
BDD	BACKDRAFT DAMPER
B.O.D.	BOTTOM OF DUCT
CONV	CONVECTOR
CFM	CUBIC FEET PER MINUTE
CWR	CHILLED WATER RETURN
CWS	CHILLED WATER SUPPLY
CU	CONDENSING UNIT
COR	CONDENSER WATER RETURN
COS	CONDENSER WATER SUPPLY
DB	DRY BULB TEMPERATURE
EA	EXHAUST AIR
EAT	ENTERING AIR TEMPERATURE
EBB	ELECTRIC BASEBOARD
ECUH	ELECTRIC CABINET UNIT HEATER
EF	EXHAUST FAN
EG	EXHAUST GRILLE
ETC	ELECTRICAL TRADES CONTRACTOR
EUH	ELECTRIC UNIT HEATER
EXH	EXHAUST
F	FURNACE
F/SD	COMBINATION FIRE/SMOKE DAMPER
G	LOW PRESSURE GAS
GPM	GALLONS PER MINUTE
HR	HEATING HOT WATER RETURN
HS	HEATING HOT WATER SUPPLY
HP	HORSEPOWER
HPS	HIGH PRESSURE STEAM SUPPLY
HVAC	HEATING/VENTILATING/AIR CONDITIONING
LAT	LEAVING AIR TEMPERATURE
LPS	LOW PRESSURE STEAM SUPPLY
MAX	MAXIMUM
MTC	MECHANICAL TRADES CONTRACTOR
MBH	BTU PER HOUR (THOUSAND)
MFR	MANUFACTURER
MPS	MEDIUM PRESSURE STEAM SUPPLY
NFPA	NATIONAL FIRE PROTECTION ASSOCIATION
OA	OUTSIDE AIR
OD	OUTSIDE DIAMETER
P	PUMP
PRV	PRESSURE REDUCING VALVE
PSC	PUMPED STEAM CONDENSATE
PSI	POUNDS PER SQUARE INCH
RA	RETURN AIR
RG	RETURN GRILLE
RL	REFRIGERANT LIQUID
RP	RADIANT PANEL
RS	REFRIGERANT SUCTION
RTU	ROOF TOP UNIT
SA	SUPPLY AIR
SC	STEAM CONDENSATE
SD	SUPPLY DIFFUSER
SG	SUPPLY GRILLE
SP	STATIC PRESSURE
TG	TRANSFER GRILLE
TU	TERMINAL UNIT
TXV	THERMAL EXPANSION VALVE
TYP	TYPICAL
UH	UNIT HEATER
VFD	VARIABLE FREQUENCY DRIVE
WB	WET BULB TEMPERATURE
X-	EXISTING
.SD-1	TAG (DIFFUSERS AND GRILLES)
8"∅	NECK SIZE
200 CFM	AIR FLOW
TYP.2	COMMENTS

NOTE:
ALL ABBREVIATIONS AND SYMBOLS SHOWN ON THIS SHEET MAY NOT BE USED ON THIS PROJECT.

PIPING SYMBOLS

	PIPE TURNED UP
	PIPE TURNED DOWN
	PIPE OUT OF TOP
	PIPE OUT OF BOTTOM
	PIPE ANCHOR
	PIPE ALIGNMENT GUIDE
	PIPE EXPANSION JOINT
	STRAINER
	UNION
	SHUT-OFF VALVE
	CHECK VALVE
	BALL VALVE
	GLOBE VALVE
	MOTOR OPERATED VALVE
	SOLENOID OPERATED VALVE
	2-WAY TEMPERATURE CONTROL VALVE
	3-WAY TEMPERATURE CONTROL VALVE
	STEAM TRAP
	CIRCUIT BALANCE VALVE
	HEATING HOT WATER SUPPLY
	HEATING HOT WATER RETURN
	CHILLED WATER SUPPLY
	CHILLED WATER RETURN
	CONDENSER WATER SUPPLY
	CONDENSER WATER RETURN
	REFRIGERANT LIQUID
	REFRIGERANT SUCTION
	CONDENSATE DRAIN
	COMPRESSED AIR
	HIGH PRESSURE STEAM 76-100 LBS.
	MEDIUM PRESSURE STEAM 21-75 LBS.
	LOW PRESSURE STEAM 0-20 LBS.
	STEAM CONDENSATE
	STEAM CONDENSATE PUMPED
	GAS PIPE - LOW PRESSURE
	GAS - HIGH PRESSURE
	GAS - MEDIUM PRESSURE
	GAS METER

GENERAL SYMBOLS

	KEY NOTE
	CONNECTION POINT, NEW TO EXISTING
	DEMOLITION END POINT

SHEET METAL SYMBOLS

	SUPPLY AIR DUCT
	RETURN AIR DUCT
	EXHAUST AIR DUCT
	BALANCE DAMPER
	CONICAL TEE
	90° TEE WITH 45° APPROACH
	TRANSITION CONCENTRIC
	TRANSITION ECCENTRIC
	VERTICAL FIRE DAMPER
	HORIZONTAL FIRE DAMPER
	VERTICAL COMBINATION FIRE SMOKE DAMPER
	HORIZONTAL COMBINATION FIRE SMOKE DAMPER
	VERTICAL SMOKE DAMPER
	HORIZONTAL SMOKE DAMPER
	MOTORIZED DAMPER
	AIR FLOW DIRECTION

CONTROL SYMBOLS

	THERMOSTAT
	TEMPERATURE SENSOR
	HUMIDISTAT
	DUCT SMOKE DETECTOR, INSTALLED BY M.T.C. PROVIDED AND WIRED BY E.T.C.

GENERAL HVAC NOTES

- PERFORM WORK IN ACCORDANCE WITH THE LATEST EDITIONS, REVISIONS, AMENDMENTS, OR SUPPLEMENTS OF APPLICABLE STATUTES, ORDINANCES, CODES OR REGULATIONS OF FEDERAL, STATE, AND LOCAL AUTHORITIES HAVING JURISDICTION IN EFFECT ON THE DATE BIDS ARE RECEIVED.
- WHERE APPROVED STANDARDS HAVE BEEN ESTABLISHED BY OSHA, UNDERWRITERS LABORATORIES, AMERICAN CODES, ASA, ASHRAE, ARI, NEC, STATE FIRE INSURANCE REGULATION BODY, NFPA OR OTHERS, THESE STANDARDS SHALL BE FOLLOWED WHETHER OR NOT INDICATED ON THE DRAWINGS AND SPECIFICATIONS.
- ALL WORK SHALL COMPLY WITH THE MICHIGAN MECHANICAL CODE AND ALL APPLICABLE LOCAL CODES.
- ALL DUCT TO BE OF 1" PRESSURE CLASS, UNLESS NOTED OTHERWISE.
- COORDINATE WITH ARCHITECTURAL AND STRUCTURAL DRAWINGS FOR EXACT LOCATION OF ROOF TOP EQUIPMENT.
- DUCTWORK SHALL BE ACOUSTICALLY LINED WITHIN 20 FT OF THE INTAKE AND/OR DISCHARGE OF A FAN.
- INSTALL VOLUME DAMPERS IN ALL BRANCH DUCTS SERVING A SINGLE GRILLE, REGISTER, OR DIFFUSER.
- INSTALL FLEXIBLE DUCT CONNECTIONS AT THE INLET AND DISCHARGE OF ALL FANS.
- MAXIMUM LENGTH OF FLEXIBLE DUCT TO AIR TERMINAL DEVICES SHALL NOT EXCEED 5'-0" IN LENGTH WITH A MAXIMUM OF ONE 90° TURN AND SHALL BE INSULATED. ELBOWS SHALL BE MIN. 1.5 RADIUS. CONNECTIONS TO TERMINAL DEVICES SHALL BE BANNED AND TAPED.
- UNDERGROUND GAS SERVICE BY UTILITY COMPANY. REFER TO CIVIL DRAWINGS. COORDINATE SERVICE, METER, ETC. LOCATIONS WITH UTILITY COMPANY.
- DUCT/PIPING LAYOUT IS SCHEMATIC. EXACT LOCATION OF DUCT/PIPING AND EQUIPMENT SHALL BE COORDINATED WITH BUILDING STRUCTURE, EQUIPMENT FURNISHED, ARCHITECTURAL DRAWINGS AND ALL OTHER TRADES PRIOR TO INSTALLATION. ANY CONTRACTOR INSTALLING WORK WITHOUT PRIOR COORDINATION SHALL RELOCATE HIS WORK AT HIS EXPENSE TO ALLOW PROPER INSTALLATION OF ANY AND ALL TRADES' WORK.
- UNLESS OTHERWISE NOTED, ALL DUCT/PIPING SHALL BE CONCEALED WHEREVER POSSIBLE. PROVIDE CHROME ESCUTCHEON OR ALUMINUM DUCT COLLAR AT EACH PENETRATION OF A FINISHED SURFACE.
- DUCT/PIPING SHALL NOT BE RUN ABOVE ELECTRICAL GEAR OR IN THE SERVICE SPACE REQUIRED BY THE NATIONAL ELECTRICAL CODE.
- DUCT SIZES SHOWN ARE NET INSIDE CLEAR DIMENSIONS.
- ANY ADDITIONAL LOW VOLTAGE CONTROL WIRING THAT IS REQUIRED SHALL BE PROVIDED BY THE HVAC CONTRACTOR. CONTROL WIRING SHALL BE RUN IN CONDUIT IF REQUIRED BY LOCAL CODES. FIELD VERIFY PRIOR TO BID. POWER WIRING SHALL BE PROVIDED BY THE ELECTRICAL CONTRACTOR.
- PROVIDE TRAP FOR CONDENSATION DRAIN LINES.
- PROVIDE VIBRATION ISOLATION AT EACH CONNECTION TO A MOTORIZED PIECE OF EQUIPMENT BY THE HVAC CONTRACTOR.
- MOUNT THERMOSTAT/SENSORS AT 48" AFF UNLESS NOTED OTHERWISE.
- THE HVAC CONTRACTOR SHALL CLOSELY COORDINATE AIR DEVICE AND DUCTWORK LOCATIONS WITH REFLECTED CEILING AND STRUCTURAL PLANS.
- COORDINATE SENSOR AND THERMOSTAT LOCATION WITH ARCHITECT.

Disclaimer: The drawings found within this set are Substantially Complete, but are marked "Not for Construction," as it will be necessary for each site-specific development to employ architects and/or engineers to evaluate local conditions, make necessary adjustments required for local permitting. Some items are indicated as blanks for local verification.

Do not scale.
Use figured
dimensions only.

MML Review Set
22 AUG 2022

NOT FOR CONSTRUCTION

THE LINDEN
Michigan Municipal League

Job Number:
2022xx

Title:
HVAC COVER
SHEET

M0.1

Disclaimer: The drawings found within this set are Substantially Complete, but are marked "Not for Construction," as it will be necessary for each site-specific development to employ architects and/or engineers to evaluate local conditions, make necessary adjustments required for local permitting. Some items are indicated as blanks for local verification.

Do not scale.
Use figured
dimensions only.
MML Review Set
22 AUG 2022

NOT FOR CONSTRUCTION

THE LINDEN
Michigan Municipal League

Job Number:
2022xx
Title:
HVAC FLOOR
PLANS

M1.1

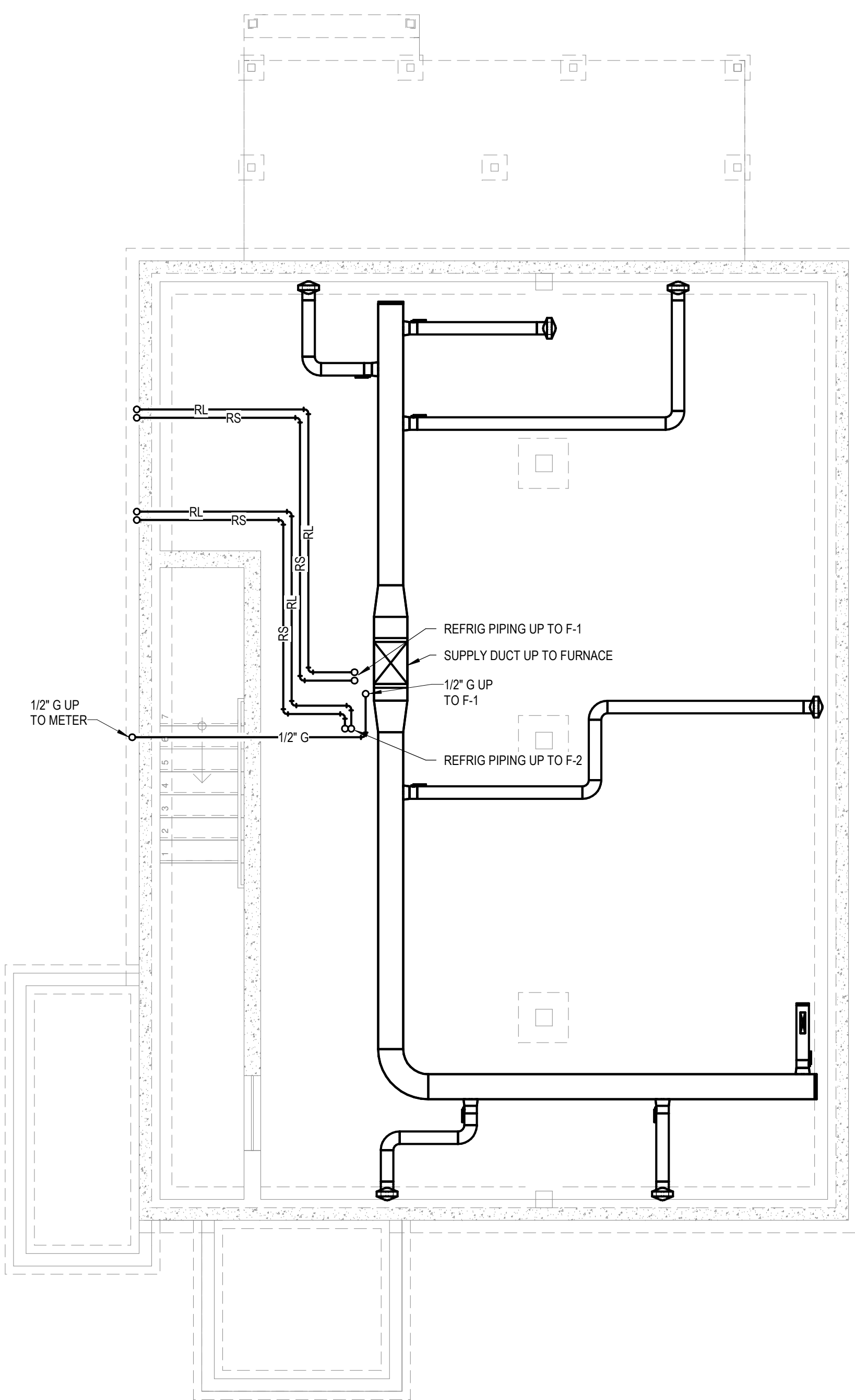

4 FOUNDATION PLAN - HVAC
M1.1 SCALE = 1/4" = 1'-0"

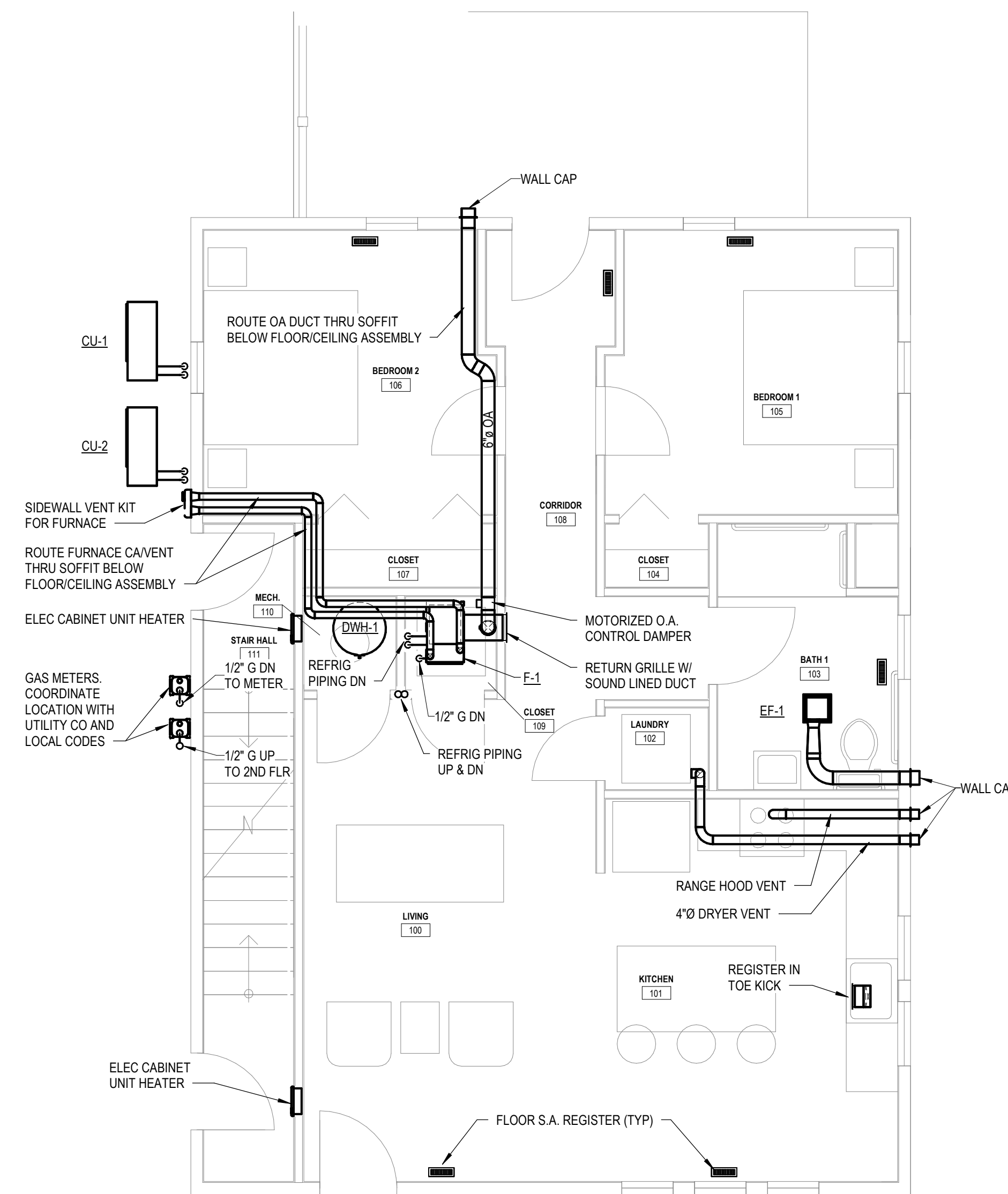

2 MAIN FLOOR PLAN - HVAC
M1.1 SCALE = 1/4" = 1'-0"

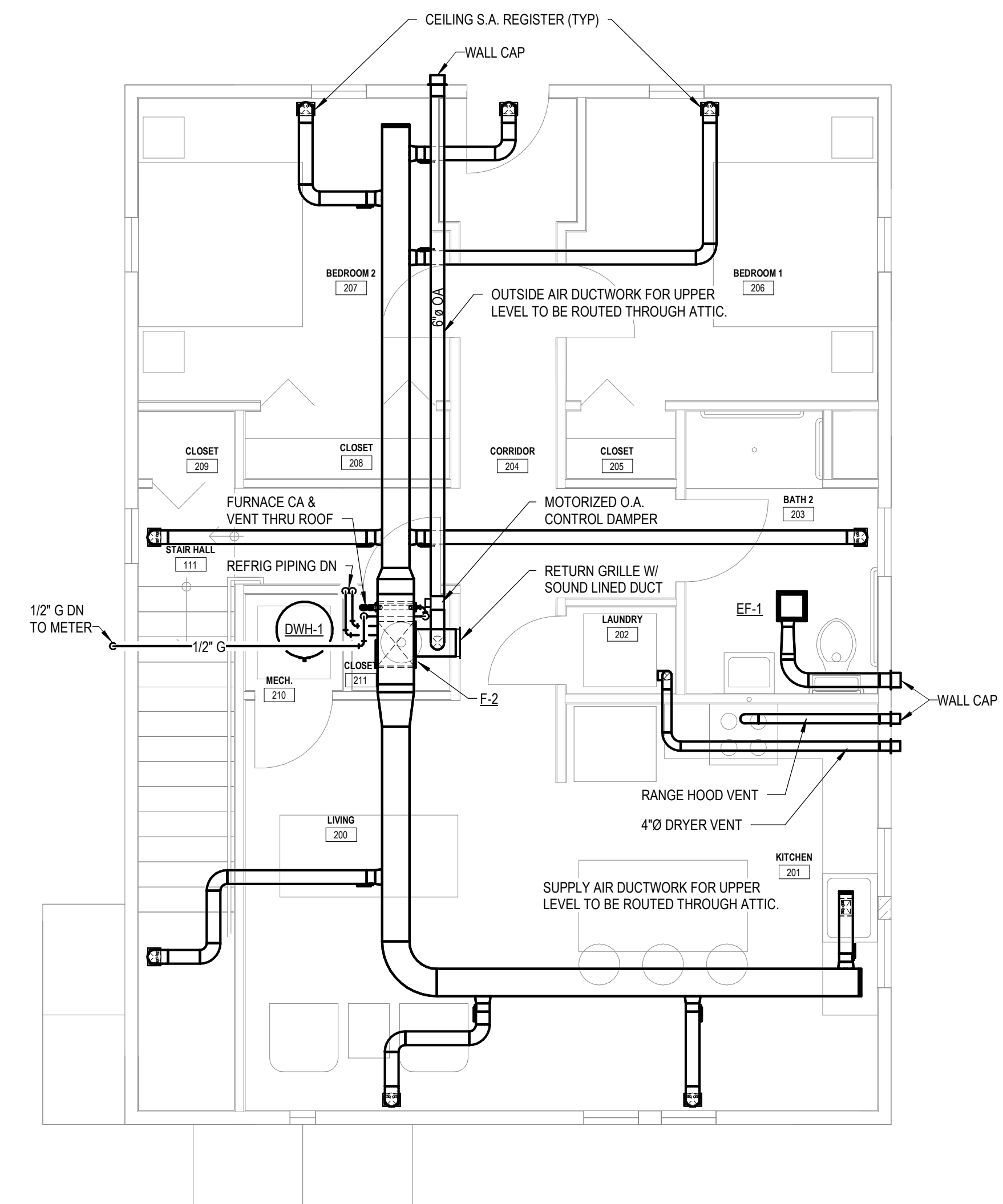

3 UPPER LEVEL FLOOR PLAN - HVAC
M1.1 SCALE = 1/4" = 1'-0"

Disclaimer: The drawings found within this set are Substantially Complete, but are marked "Not for Construction," as it will be necessary for each site-specific development to employ architects and/or engineers to evaluate local conditions, make necessary adjustments required for local permitting. Some items are indicated as blanks for local verification.

Do not scale.
Use figured
dimensions only.
MML Review Set
22 AUG 2022

NOT FOR CONSTRUCTION

EXHAUST FAN SCHEDULE

COMMENTS:
1. PROVIDE WITH ELECTRONICALLY COMMUTATED MOTOR WITH CONSTANT CFM ADAPTIVE, VARIABLE SPEED TECHNOLOGY PROGRAMMED TO OVERCOME THE STATIC PRESSURE ASSOCIATED WITH COMMON RESIDENTIAL INSTALLATION SCENARIOS.
2. PROVIDE WITH WALL CAP INCLUDING BIRDSCREEN AND BACKDRAFT DAMPER.

TAG	BASIS OF DESIGN		CFM	E.S.P. (in-wg)	FAN SPEED (RPM) DESIGN	DRIVE TYPE	SONES	ELECTRICAL DATA		DISCONNECT BY		VFD	CONTROL	COMMENTS
	MANUFACTURER	MODEL						WATTS	VOLTAGE	M.T.C.	E.T.C.			
EF-1	Greenheck	SP-LP0511	80	0.28	831	DIRECT	2	11	120V / 1Ø	X			LOCAL SWITCH	1, 2

FURNACE SCHEDULE

COMMENTS:
1. PROVIDE WITH 1" MERV 8 FILTER.
2. UNIT SHALL COMMUNICATE WITH CONDENSING UNIT TO MATCH CAPACITY TO DEMAND AND FURNACE FAN SPEED.
3. UNIT SHALL HAVE ELECTRONICALLY COMMUTATED MOTOR (ECM) FOR SUPPLY FAN.
4. PROVIDE 7-DAY / 4-PERIOD THERMOSTAT.
5. CONNECT MOTORIZED OUTSIDE AIR DAMPER TO SUPPLY FAN CONTROL. DAMPER SHALL OPEN WHEN FAN IS RUNNING.
6. PROVIDE WITH CASED COOLING COIL WITH CONDENSATE DRAIN. COIL SHALL BE SAME MANUFACTURER AS FURNACE AND CONDENSING UNIT.
7. VERIFY CAPACITY WITH LOCAL CLIMATE DESIGN CONDITIONS, SITE ORIENTATION, AND ENERGY CODE.

TAG	BASIS OF DESIGN		DESCRIPTION	SUPPLY FAN DATA		COOLING COIL DATA		HEATING DATA				ELECTRICAL DATA			DISCONNECT BY		COMMENTS
	MANUFACTURER	MODEL No.		SUPPLY AIR	OUTSIDE AIR	NOM. TONS	TOTAL BTU/H	INPUT BTU/H MAX	MIN	OUTPUT BTU/H MAX	MIN	H.P.	MOCP	VOLTAGE	M.T.C.	E.T.C.	
F-1	Daikin	DC96VC	DOWNFLOW, GAS-FIRED FURNACE	700 CFM	45 CFM	1.5	17	40		38		1/2	15	120V / 1Ø	X		1, 2, 3, 4, 5, 6, 7
F-2	Daikin	DM96VC	UPFLOW, GAS-FIRED FURNACE	700 CFM	45 CFM	1.5	17	40		38		1/2	15	120V / 1Ø	X		1, 2, 3, 4, 5, 6, 7

CONDENSING UNIT SCHEDULE

COMMENTS:
1. PROVIDE WITH INVERTER (VARIABLE SPEED) COMPRESSOR.
2. UNIT SHALL COMMUNICATE WITH FURNACE TO MATCH CAPACITY TO DEMAND AND FURNACE FAN SPEED.
3. VERIFY CAPACITY WITH LOCAL CLIMATE DESIGN CONDITIONS, SITE ORIENTATION, AND ENERGY CODE.

TAG	BASIS OF DESIGN		DESCRIPTION	REFRIGERANT	COOLING - MBH	TONS	SEER	ELECTRICAL DATA			DISCONNECT BY		COMMENTS
	MANUFACTURER	MODEL						MCA	MOCP	VOLTAGE	M.T.C.	E.T.C.	
CU-1	Daikin	DX17VSS181AA	Split System Air Conditioner	R-410A	17.1	1.5	17	12.7	15	208-230V / 1Ø			1, 2, 3
CU-2	Daikin	DX17VSS181AA	Split System Air Conditioner	R-410A	17.1	1.5	17	12.7	15	208-230V / 1Ø	X		1, 2, 3

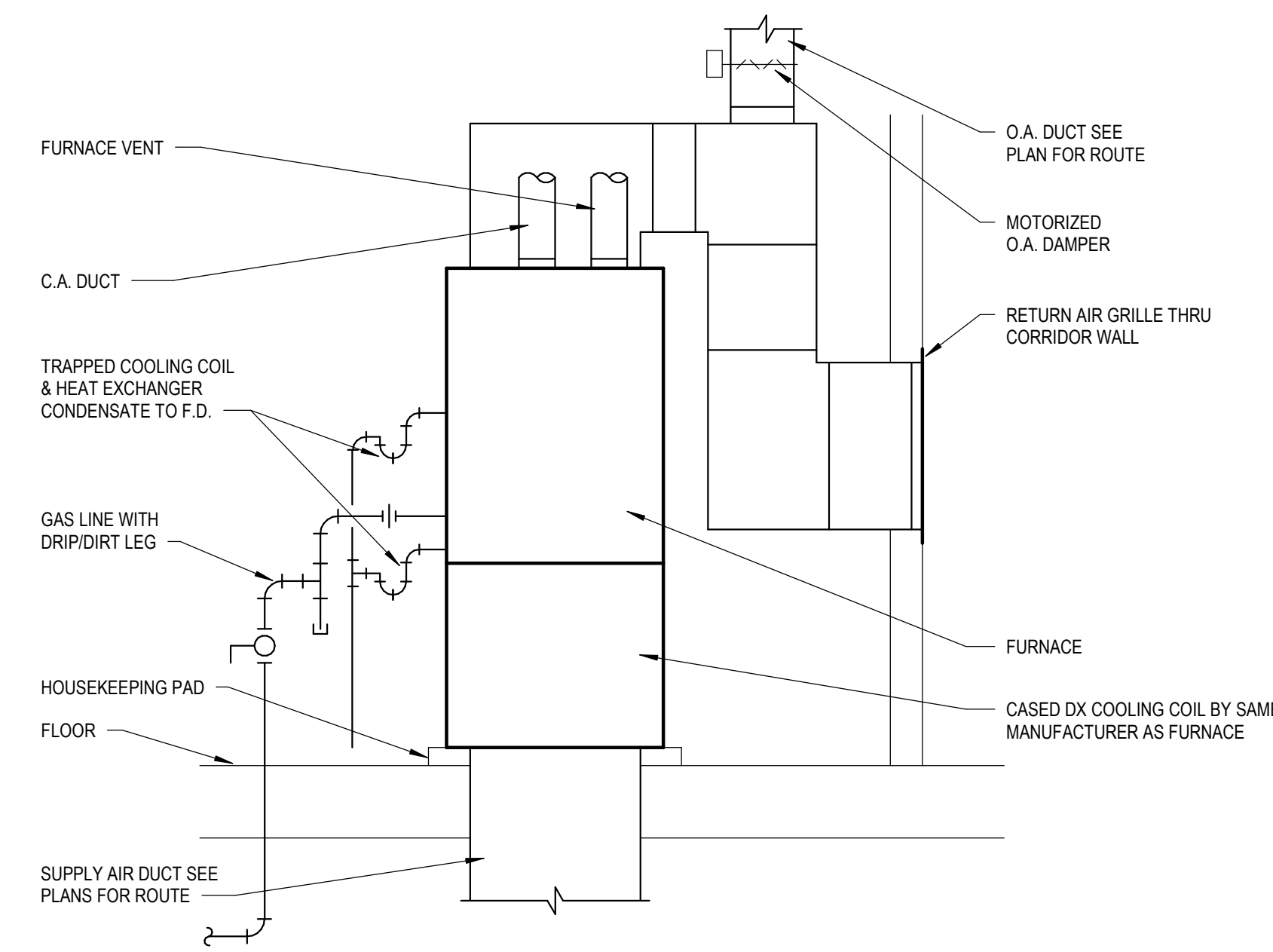

1 DOWNFLOW FURNACE DETAIL
M6.1 SCALE = 12" = 1'-0"

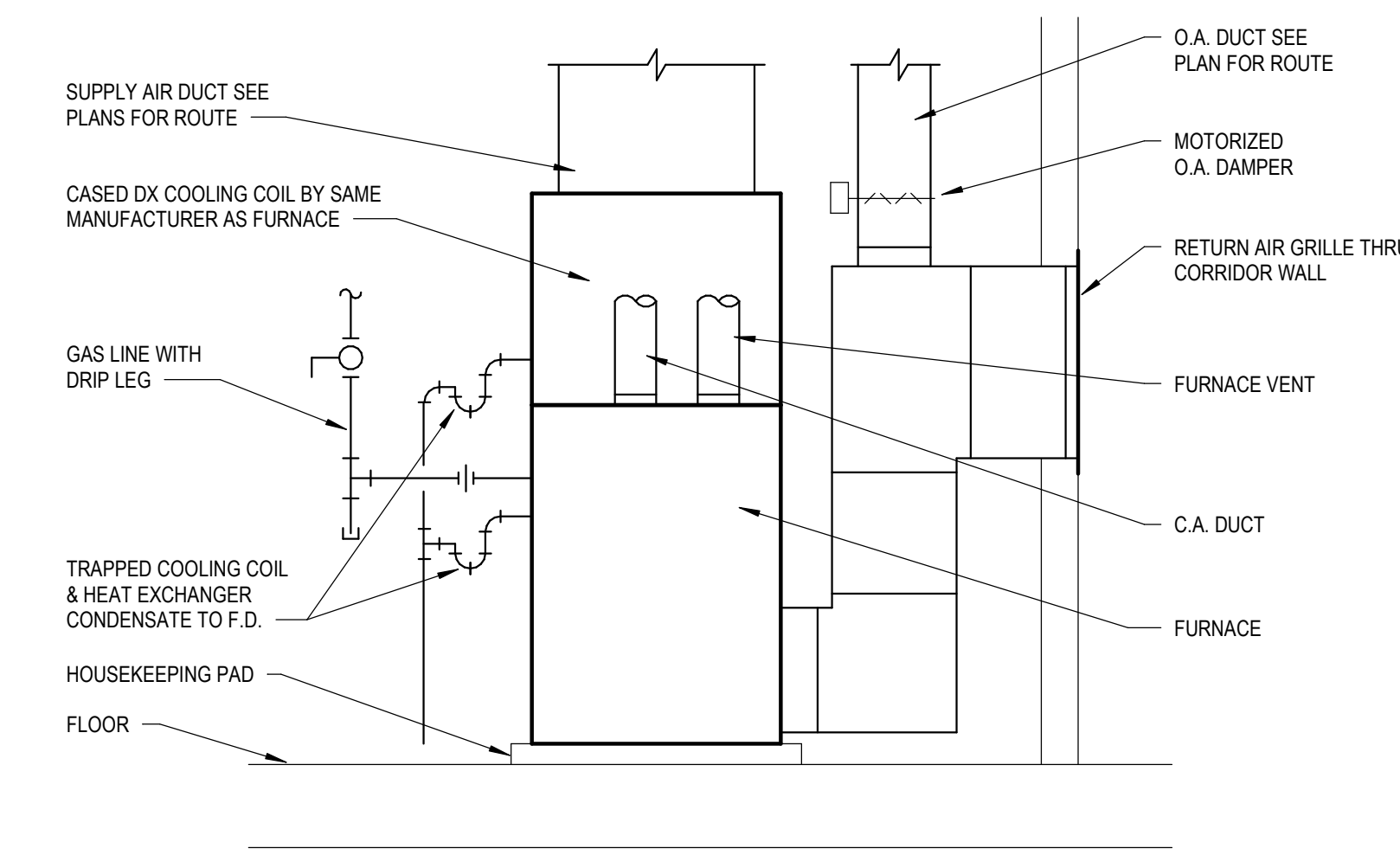

2 UPFLOW FURNACE DETAIL
M6.1 SCALE = 12" = 1'-0"

THE LINDEN
Michigan Municipal League

Job Number:
2022xx
Title:
HVAC DETAILS & SCHEDULES

M6.1